



MASGAMES PARQUE LOLLIPOP L

MA700425X

MASGAMES PARQUE LOLLIPOP XL

MA700428X



MASGAMES ACTIVE TOYS S.L.
Carrer Tona, 14, 08480 L'Ametlla del Vallès, Barcelona, España.

+34 902 104 314 +34 935 686 506

info@masgames.com

+34 650 50 11 40



Follow us!



ESPAÑOL

Apreciado cliente,

Este producto ha sido diseñado y fabricado de acuerdo con los requisitos de seguridad de la normativa europea EN71-1, EN71-2, EN71-3 y EN71-8.

INSTRUCCIONES DE SEGURIDAD DURANTE EL MONTAJE

Respetar escrupulosamente las instrucciones de montaje. Conservar las instrucciones para consultarlas en caso de necesidad, especialmente para la identificación de los componentes.

ADVERTENCIA. Se requiere ensamblaje por un adulto.

ADVERTENCIA. Durante el montaje mantener alejados a los niños y niñas.

ADVERTENCIA. Antes del montaje asegurar que el kit esté completo. Si el kit no está completo contacte con el fabricante.

Asegurar disponer de un espacio amplio, plano y despejado para el montaje.

ADVERTENCIA. Limpiar bien cada componente de madera de posibles astillas.

ADVERTENCIA. Es imprescindible pretaladrar todas las maderas para evitar grietas.

Son necesarias dos personas para montar el producto.

INSTRUCCIONES DE SEGURIDAD DURANTE EL USO

El uso de este juguete debe estar bajo la supervisión de un adulto que debe garantizar que los niños que usan el juguete tienen la edad y la capacidad para hacerlo.

ADVERTENCIA. Producto no conveniente para niños y niñas menores de 36 meses. Piezas pequeñas, elementos desmontables.

ADVERTENCIA. Producto para niños y niñas de entre 3 a 12 años.

MANTENIMIENTO

Para evitar que su producto se convierta en un peligro durante su uso, le pedimos revisar todos los meses:

- La torsión de los tornillos. Apretar cada tornillo y tuerca si es necesario.
- La aparición de astillas en componentes de madera, lijelas si es necesario.
- Las partes metálicas no requieren ningún mantenimiento en particular. Sin embargo, según la zona geográfica (orillas del mar), algunos revestimientos pueden estropearse. En caso de corrosión de algunos componentes, evitar la herrumbre con ayuda de un producto adecuado.

INFORMACIÓN SOBRE LA MADERA: NORMATIVAS, CALIDAD Y ESTÉTICA DE LA MADERA

- Todos los componentes de madera se someten al tratamiento autoclave. El proceso consiste en la inyección de un agente químico protector en un tanque a alta presión. El producto entra en el corazón de la madera asentándose permanentemente. Este proceso está certificado y garantiza la conservación de la madera contra hongos y los ataques de insectos durante 10 años.
- La madera es un material fibroso, las variaciones de temperatura y humedad pueden causar contracciones y dilataciones que originen pequeñas grietas. Estas grietas no alteran la resistencia mecánica del componente porque están en la dirección de las fibras de madera. Como consecuencia, dichas fisuras no entran dentro del marco de la garantía.
- Cuando la madera está húmeda, puede formar una película negruzca o blanquecina. Cuando esta película esté seca, habrá que cepillarla para hacerla desaparecer.
- Dependiendo del grado de humedad del aire, la sección de la madera puede aumentar (alta humedad) o disminuir (baja humedad). Las tolerancias del diseño tienen en cuenta estos fenómenos. El espacio entre maderas puede, en ciertos casos, alcanzar varios milímetros: no intercalar ningún producto (cuña, masilla, ...) en este espacio libre.

Es necesario pretaladrar todas las maderas para evitar grietas.

Los parques infantiles MASGAMES están pensados para que las familias los monten en casa. Todos vienen con instrucciones con los pasos a seguir para un correcto montaje. Aunque las instrucciones son claras sobre como montar los juegos no todo el mundo sabe cómo hacer correctamente agujeros en la madera, organizar el montaje o las características de la madera.

En el canal de YOUTUBE de MASGAMES tenemos varios vídeos de como montar los parques infantiles y los columpios.



www.youtube.com/masgamesactivetoyss



ADVERTENCIA



ENGLISH

Dear Client,

This product has been designed and manufactured in accordance with the safety requirements of European regulations EN71-1, EN71-2, EN71-3 and EN71-8.

SECURITY INSTRUCTIONS DURING ASSEMBLY

Scrupulously observe the assembly instructions. It is essential to keep the instructions to consult them if necessary, especially for the identification of the components.

WARNING. Assembly by an adult is required.

WARNING. During assembly keep children away.

WARNING. Before the assemble make sure the kit is complet. In case of missing component contact with the producer. Before mounting, make sure that the area where it will be located is a flat, horizontal and free of obstructions space.

WARNING. Before and after assembly: clean each wooden component well from possible chips that may have appeared.

WARNING. All woods must be pre-drilled to avoid cracks.

Two people are required to assemble the product.

SECURITY INSTRUCTIONS DURING EVERYDAY USE

The use of this toy must be under the constant supervision of an adult who must guarantee the children who use the toy are of the age and capacity to do so.

WARNING. Not suitable for children under 3 years of age. Small parts, demountable bodies.

WARNING. For children from 3 to 12 years old.

MAINTENANCE

To prevent your product from becoming a hazard during use, we ask that you check it every month:

- Tighten each bolt and nut if necessary.
- The appearance of chips in wooden components, sand them if necessary.
- The metal parts do not require any particular maintenance. However, depending on the geographical area (seaside), some coatings can be damaged. In case of corrosion of some components, avoid rust with the help of a suitable product.

INFORMATION ABOUT WOOD: REGULATIONS, QUALITY AND AESTHETICS OF WOOD

- All wood components are subjected to an autoclave treatment. The process involves injecting a protective chemical into a high-pressure tank. The product enters the heart of the wood by settling permanently. This process is certified and guarantees the preservation of the wood against fungi and insect attacks for 10 years.
- Wood is a fibrous material, variations in temperature and humidity can cause longitudinal cuts. These cracks do not alter the mechanical strength of the component because they are in the direction of the wood fibers. As a consequence, these cracks do not fall within the scope of the guarantee.
- When wood is wet, it can form a blackish film. When this film is dry, it will have to be brushed to make it disappear.
- Depending on the degree of humidity in the air, the diameter of the logs may increase (very humid air) or decrease (very dry air). The tolerance of the internal diameters of the connection angles takes these phenomena into account. The space between the trunk and the angle can, in certain cases, reach several millimeters: do not insert any product (wedge, putty, ...) in this free space.

All woods must be pre-drilled to avoid cracks.

MASGAMES playgrounds are designed to be assembled by families at home. They all come with visual instructions of the montage. Although the instructions are clear on how to assemble the games, not everyone knows how to correctly drill holes in the wood, organize the assembly or the characteristics of the wood.

On the YOUTUBE channel of MASGAMES we have several videos on how to set up playgrounds and swings.



www.youtube.com/masgamesactivetoyssl



WARNING



FRANÇAIS

Cher client,

Ce produit a été conçu et fabriqué conformément aux exigences de sécurité des réglementations européennes EN71-1, EN71-2, EN71-3 et EN71-8.

INSTRUCTIONS DE SÉCURITÉ DE MONTAGE

Respectez scrupuleusement les instructions de montage. Il est indispensable de les conserver pour les consulter si nécessaire, notamment pour l'identification des composants.

ATTENTION. L'assemblage par un adulte est requis.

ATTENTION. Pendant le montage, éloignez les enfants.

ATTENTION. Avant du assamblage, assurez-vous que le kit est complet. Si le kit n'est pas complet, contactez-nous.

Avant le montage, assurez-vous que la zone où il sera situé est: un espace plat, horizontal i libre d'obstacles.

ATTENTION. Avant et après l'assemblage, nettoyez bien chaque composant en bois de tous les éclats qui ont pu apparaître lors de l'assemblage en utilisant du papier de verre pour ce matériau.

ATTENTION. Tous les bois doivent être pré-perçés pour éviter les fissures.

Deux personnes sont nécessaires pour assembler le produit.

INSTRUCTIONS DE SÉCURITÉ D'UTILISATION

L'utilisation de ce jouet doit se faire sous la surveillance d'un adulte qui doit garantir que les enfants qui utilisent le jouet ont l'âge et la capacité de le faire.

ATTENTION. Ne convient pas aux enfants de moins de 36 mois. Petits elements.

ATTENTION. Jouet per infants jusqu'à 12 ans.

ENTRETIEN

Pour éviter que votre produit ne devienne un danger lors de son utilisation, nous vous demandons de le vérifier tous les mois:

- Serrez chaque boulon et écrou si nécessaire.
- L'apparition de copeaux dans les composants en bois, poncez-les si nécessaire.
- Les pièces métalliques ne nécessitent aucun entretien particulier. Cependant, selon la zone géographique (bord de mer), certains revêtements peuvent être endommagés. En cas de corrosion de certains composants, éviter la rouille à l'aide d'un produit adapté.

INFORMATIONS SUR LE BOIS: RÉGLEMENTATION, QUALITÉ ET ESTHÉTIQUE DU BOIS

- Tous les composants en bois sont soumis à un traitement autoclave qui consiste en une extraction sous vide de toute l'humidité contenue dans le bois. Le traitement autoclave est injecté sous pression. Le traitement pénètre jusqu'à le coeur du bois et reste à l'intérieur en permanence. Ce procédé est certifié et garantit la préservation du bois contre les attaques de champignons et d'insectes pendant 10 ans.
- Le bois est un matériau fibreux, les variations de température et d'humidité peuvent provoquer des coupes longitudinales. Ces fissures n'altèrent pas la résistance mécanique du composant car elles sont dans le sens des fibres du bois. En conséquence, ces fissures n'entrent pas dans le champ d'application de la garantie.
- Lorsque le bois est mouillé, il peut former un film noirâtre. Lorsque ce film est sec, il faudra le brosser pour le faire disparaître.
- Selon le degré d'humidité de l'air, le diamètre des bûches peut augmenter (air très humide) ou diminuer (air très sec). La tolérance des diamètres intérieurs des angles de connexion tient compte de ces phénomènes. L'espace entre le tronc et l'angle peut, dans certains cas, atteindre plusieurs millimètres: n'insérez aucun produit (cale, mastic, ...) dans cet espace libre.

Tous les bois doivent être pré-perçés pour éviter les fissures.

Les parcs pour enfants Masgames sont conçues afin que les familles puissent facilement les assembler. Ils viennent tous avec des instructions avec les étapes que les montages doivent suivre. Bien que les instructions soient claires sur la façon d'assembler les jeux, tout le monde ne sait pas comment percer correctement des trous dans le bois, organiser l'assemblage ou les caractéristiques du bois.

Dans la chaîne YOUTUBE de MASGAMES, nous avons plusieurs vidéos sur la façon de mettre en place des terrains de jeux et des balançoires.



www.youtube.com/masgamesactivetoyssl



ATTENTION



PORTUGUÊS

Caro cliente,

Este produto foi projetado e fabricado de acordo com os requisitos de segurança dos regulamentos europeus EN71-1, EN71-2, EN71-3 e EN71-8.

INSTRUÇÕES DE SEGURANÇA NA MONTAGEM

Observe escrupulosamente as instruções de montagem. É imprescindível guardar as instruções para consultá-los se necessário, principalmente para a identificação dos componentes.

ATENÇÃO. A montagem por um adulto é necessária.

ATENÇÃO. Durante a montagem, mantenha as crianças afastadas.

ATENÇÃO. Antes da montagem certifique que o conteúdo do kit é completo. Contacte com o fabricante se falta algum elemento.

Antes da montagem, certifique-se de que a área onde ficará localizada é um espaço plano, horizontal e livre de obstáculos.

ATENÇÃO. Limpe bem cada componente de madeira de quaisquer lascas antes e depois da montagem.

São necessárias duas pessoas para montar o produto.

INSTRUÇÕES DE SEGURANÇA DA UTILIZAÇÃO

O uso deste brinquedo deve ser feito sob a supervisão de um adulto que deve garantir que as crianças que usam o brinquedo são da idade e capacidade para fazê-lo.

ATENÇÃO. Não é adequado para crianças menores de 36 meses. Peças pequenas, elementos desmontáveis.

ATENÇÃO. Para crianças dos 3 aos 12 anos.

MANUTENÇÃO

Para evitar que seu produto se torne um perigo durante o uso, pedimos que você o verifique todos os meses:

- Aperte cada parafuso e porca, se necessário
- O aparecimento de aparas em componentes de madeira, lixe-as se necessário.
- As peças de metal não requerem nenhuma manutenção especial. No entanto, dependendo da área geográfica (litoral), alguns revestimentos podem ser danificados. Em caso de corrosão de alguns componentes, evite a ferrugem com o auxílio de um produto adequado.

INFORMAÇÕES SOBRE A MADEIRA: REGULAMENTOS, QUALIDADE E ESTÉTICA DA MADEIRA

- Todos os componentes da madeira são submetidos a um tratamento de autoclave. O processo envolve a injeção de um produto químico protetor em um tanque de alta pressão. O químico entra no coração da floresta estabelecendo-se permanentemente. Este processo é certificado e garante a preservação da madeira contra o ataque de fungos e insetos por 10 anos.
- A madeira é um material fibroso, variações de temperatura e umidade podem causar contrações e dilatações que causam cortes longitudinais. Essas fissuras não alteram a resistência mecânica do componente, pois estão na direção das fibras da madeira. Como consequência, essas fissuras não são abrangidas pela garantia.
- Quando a madeira está molhada, pode formar uma película escura. Quando este filme estiver seco, terá que ser escovado para que desapareça.
- Dependendo do grau de umidade do ar, a secção pode aumentar (ar muito úmido) ou diminuir (ar muito seco). A tolerância dos desings levam esses fenômenos em consideração. O espaço entre as madeiras pode, em certos casos, atingir vários milímetros: não insira nenhum produto (cunha, massa, ...) neste espaço livre.

Todas as madeiras devem ser pré-perfuradas para evitar rachaduras.

Os parques infantis da Masgames são projetados para instalar em uma casa particular. Todos eles vêm com instruções que as pessoas que vão montar o parque devem seguir. Embora as instruções de montagem dos jogos sejam claras, nem todos sabem fazer corretamente os furos na madeira, organizar a montagem ou as características da madeira.

No canal YOUTUBE da MASGAMES temos vários vídeos sobre como montar playgrounds e balanços.



www.youtube.com/masgamesactivetoyssl



ATENÇÃO



CATALÀ

Benvolgut client,

Aquest producte ha estat dissenyat i fabricat d'acord amb els requisits de seguretat de la normativa europea EN71-1, EN71-2, EN71-3 i EN71-8.

INSTRUCCIONS DE SEGURETAT DURANT EL MUNTATGE

Respectar escrupolosament les instruccions de muntatge. Conservar les instruccions per consultar-les en cas de necessitat, especialment per a la identificació dels components.

ADVERTÈNCIA. Pel muntatge es requereix d'un adult.

ADVERTÈNCIA. Durant el muntatge mantenir allunyats els nens i nenes.

ADVERTÈNCIA. Abans d'iniciar el muntatge, revisi el contingut del kit. Si el kit no estigués complet contacti amb el fabricant.

Assegurar que disposa d'un espai ample, pla i lliure d'obstacles per dur a terme el muntatge.

ADVERTÈNCIA. Netejar bé cada component de fusta de possibles estelles tant a l'inici com al final del muntatge

ADVERTÈNCIA. És imprescindible pre-foradar totes les fustes per evitar esquerdes.

Són necessàries dues persones per muntar el producte.

INSTRUCCIONS DE SEGURETAT DURANT EL SEU ÚS

L'ús d'aquesta joguina ha d'estar sota la supervisió d'un adult que ha de garantir que els infants que fan servir la joguina tenen l'edat i la capacitat per fer-ho.

ADVERTÈNCIA. Producte no destinat a menors de 36 mesos. Peces petites, elements desmontables.

ADVERTÈNCIA. Per a infants de 3 a 12 anys.

MANTENIMENT

Per evitar que el seu producte es converteixi en un perill durant el seu ús, li demanem que el revisi tots els mesos:

- La torsió dels cargols. Apretar-los si fos necessari.
- L'aparició d'estelles a la fusta, llimi-les en cas que apareguin.
- Les parts metàl·liques no requereixen cap manteniment en particular. No obstant això, segons la zona geogràfica (la vora del mar), alguns revestiments poden fer-se malbé. En cas de corrosió d'alguns components, evitar el rovell amb ajuda d'un producte adequat.

INFORMACIÓ SOBRE LA FUSTA: NORMATIVES, QUALITAT I ESTÈTICA DE LA FUSTA

- Tots els components de fusta se sotmeten al tractament autoclau. El procés consisteix en la injecció d'un agent químic protector en un tanc a alta pressió. El producte entra al cor de la fusta assentant-s'hi permanentment. Aquest procés està certificat i garanteix la conservació de la fusta contra fongs i atacs d'insectes durant 10 anys.
- La fusta és un material fibrós, les variacions de temperatura i humitat poden causar contraccions i dilatacions que oginin talls longitudinals. Aquestes esquerdes no alteren la resistència mecànica del component perquè estan en la direcció de les fibres de fusta. Com a conseqüència, aquestes fissures no entren dins el marc de la garantia.
- Quan la fusta està humida, pot formar una pel·lícula negrosa. Quan aquesta pel·lícula estigui seca, caldrà raspallar-la per fer-la desaparèixer.
- En funció del grau d'humitat de l'aire, la secció de fusta pot augmentar (aire molt humit) o disminuir (aire molt sec). La tolerància dels dissenys té en compte aquests fenòmens. L'espai entre fustes pot, en certs casos, arribar a diversos mil·límetres: no intercalar cap producte (falca, massilla, ...) en aquest espai lliure.

Cal pre-foradar totes les fustes per evitar fissures.

Els parcs infantils MASGAMES estan pensats per a què les famílies els puguin muntar a casa. Tots ells vénen amb les instruccions de muntatge amb els passos indicats. Tot i que les instruccions són clares no tothom sabrà com fer els forats correctament, organitzar el muntatge o conèixer les característiques de la fusta.

Al canal de YOUTUBE de MASGAMES tenim vídeos que expliquen com muntar parcs infantils i gronxadors.













www.youtube.com/masgamesactivetoyssl





ADVERTÈNCIA







Contenido del kit LOLLIPOP / Kit content LOLLIPOP

Ref.	Ancho	Grueso	Largo	Units.
LA	45	45	1350	1
LB	45	45	1220	4
LC	45	45	1035	2
LD	45	45	855	4
LE	95	15	1450	18
LF	95	15	1350	8
LG	95	15	1200	16
LI	95	15	1050	6
LJ	95	15	805	2
LK	95	15	530	2
			 	
LL	95	15	460	4
			 	
LM	95	15	440	12
			 	
LN	95	15	380	6
LO	95	15	355	4
			 	
LP	95	15	355	14
LQ	95	15	250	4
			 	
LT	45	15	850	2
LU	45	15	440	1

Contenido del kit LOLLIPOP / Kit content LOLLIPOP

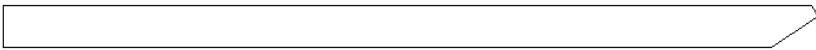
Ref.	Ancho	Grueso	Largo	Units.
LV	530	95	15	3
				
LW	45	15	1160	1
				
LX	45	15	1010	2
				

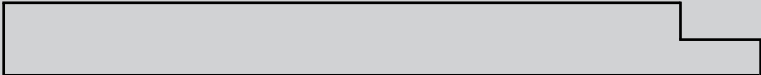
Contenido del kit TORRE / Kit content TOWER

Ref.	Ancho	Grueso	Largo / L	Largo / XL	Units L	Units XL
TA	68	68	1769	2054		4
TB	68	68	1782			2
TC	68	68	1669			5
TD	68	68	1059	1344		1
TE	68	68	627			1
TF	68	68	450			8
						
TG	68	34	1782			1
TH	68	34	1329	1727		2
						
TI	68	34	1373	1713		2
						
TJ	68	34	1669			1
TK	68	34	850			2
TL	68	34	710			2
TM	68	34	627			1
						
TN	68	34	439			1
TO	68	34	343		0	2
						
TP	68	34	242			10
						
TQ	34	95	500		5	6
TR	95	15	1918			21
TS	68	15	1782			2
TT	95	15	1835			4
TU	95	15	710			16
TV	95	15	636		10	13
TW	40	15	1918			1
TX	45	45	1230			1
TY	45	45	1110			2

Kit conector columpio

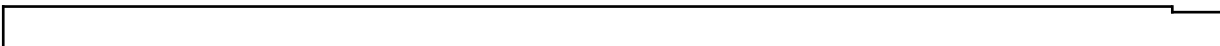
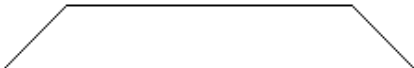
Ref.	Ancho	Grueso	L	XL	Units.
LW	68	68	2200	2485	1
					
LX	68	68	900		1
					

Ref.	Description	LOLLIPOP XL	Units L	Units XL	Annex. Columpio
AA	Ventana / Window / Fenêtre / Janela / Finestra	2			
BB	Pentágono / Pentagon / Pentagone / Pentágono / Pentàgon	1			
CC	Presas de escalara / Climbing hold / Prises d'escalade / Rochas de escalada / Peces d'escalada				
DD	Tapón antivandálico/Screw cap/Vis de Chapeau/Tampão do parafuso / Tap antivandàlic				
EE	Maceta / Flower pot / Pot de fleur / Vaso de flores / Test	1			2
FF	Mesa / Table / Tabela / Taula	1			
GG	Anclaje simple / Simple anchorage / Ancre simple / Ancoragem simple / Ancoratge simples			2	
HH	Anclaje largo / Threaded anchorage / Ancre fileté / Ancoratge llarg			2	
II	Tobogán / Slide / Toboggan / Tobogão / Togoban			1	
ZZ	Taco de madera / Wooden block / Cale de bois / Blocode madeira / Taco de fusta 68 mm			2	
a	DIN 7505-A	12	23		
b	DIN 7505-A	140	313	333	4
c	DIN 7505-A	275	15		
d	DIN 7505-B	72	22		2
e	DIN 7505-A	2	32		2
f	DIN 7505-A				
g	DIN 7505-A		2		
h	DIN 571		2		
k	DIN 571		14		
l	DIN 933	2			
m	DIN 985	2			
o	DIN 985				
p	DIN 125	2	2		
q	DIN 125				
q'	DIN 125	2			
r	DIN 603				
s	Tornillo TORX / TORX Screw / TORX bis / Parafuso TORX / Cargol TORX 8x40		48		
u	Escuadras/Corner Braces/Reinforts d'angle/Suportes de Canto/ Escaires		4		
v	Escuadras grandes /Large corner Braces/Reinforts d'angle grandes/Ample Suportes de Canto/Escaleres grans		20		

Dimensiones del producto

Product dimensions

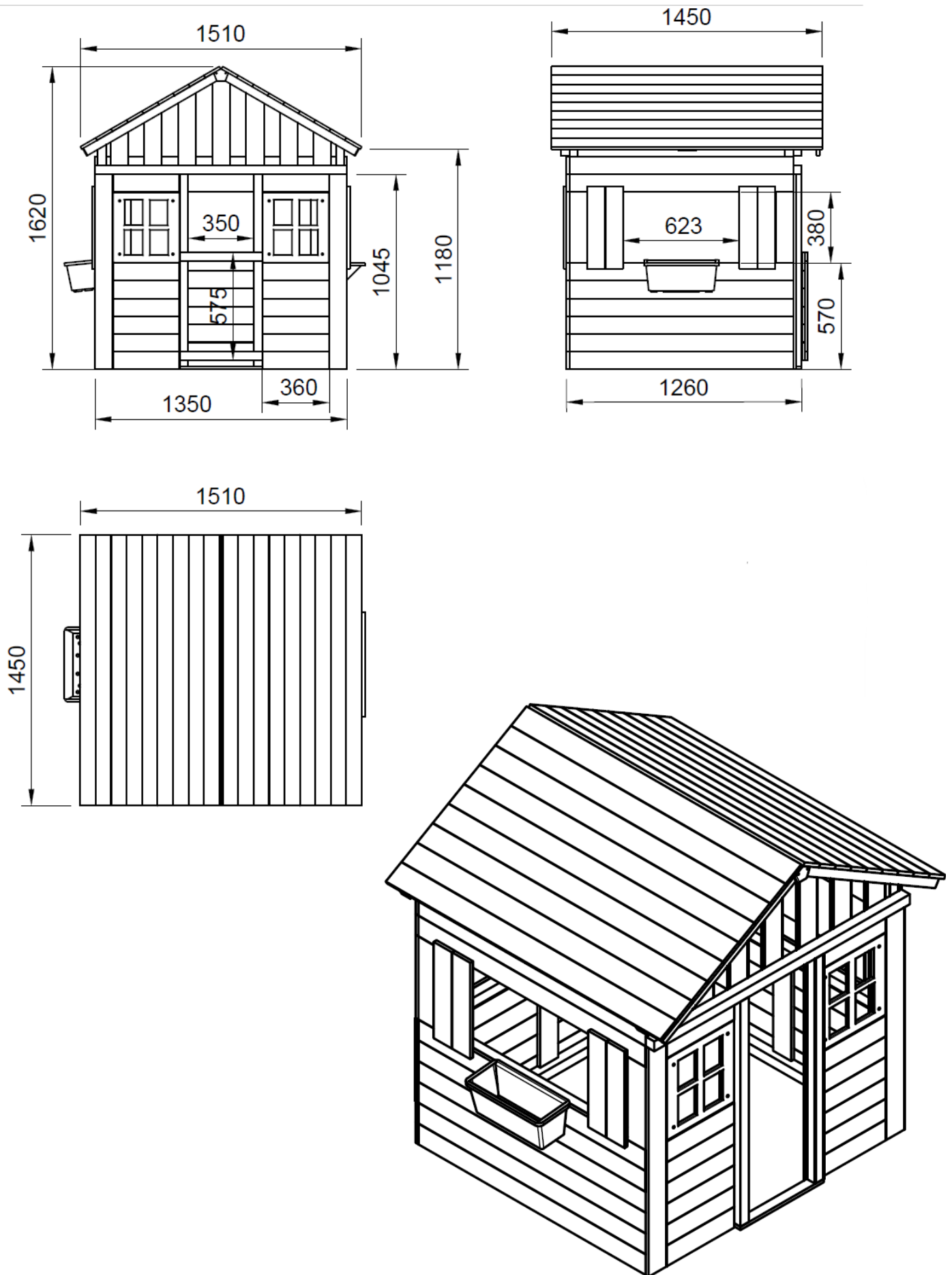

Dimensiones del producto L

Product dimensions L

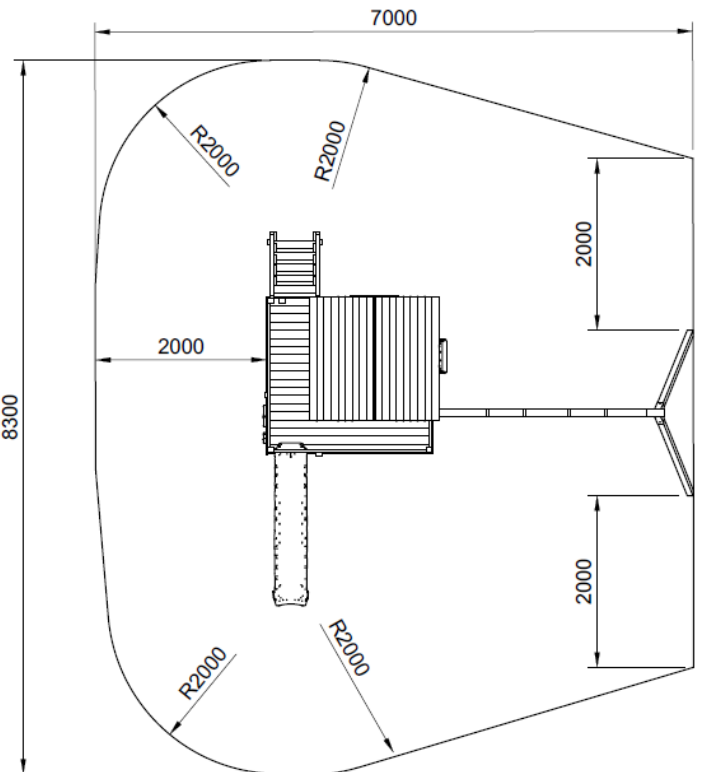
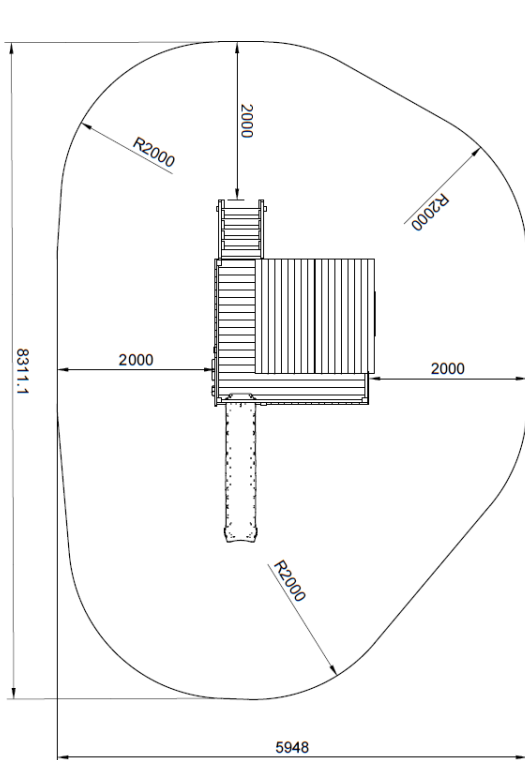
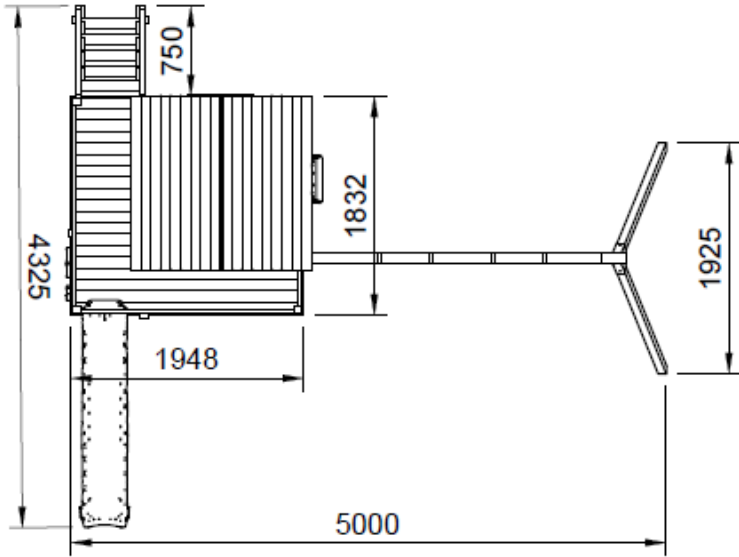
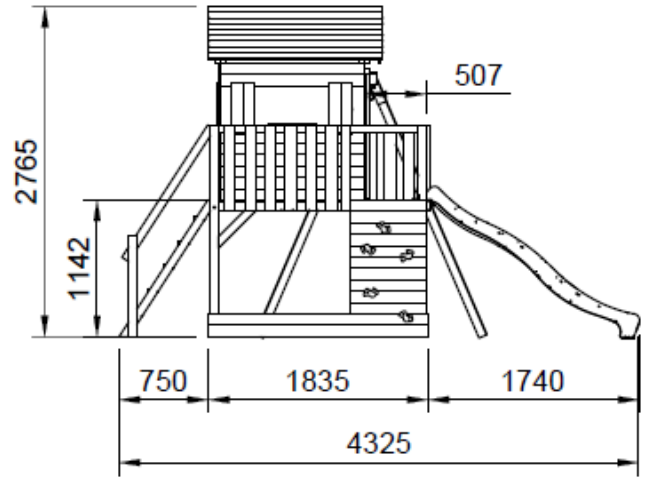
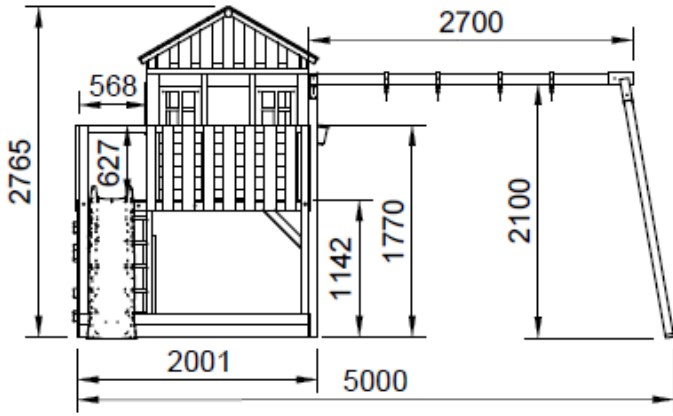

Dimensiones del producto XL

Product dimensions XL

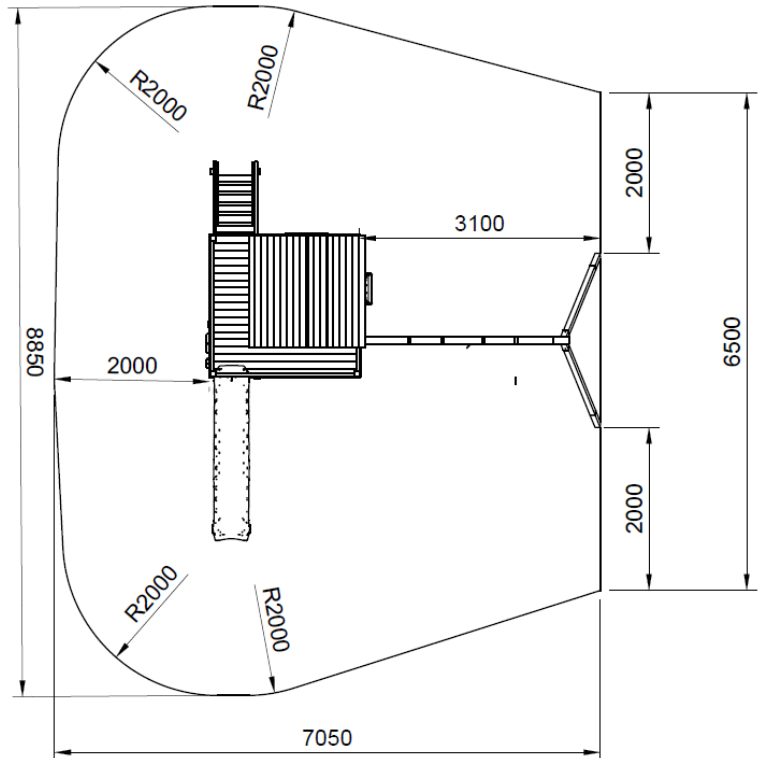
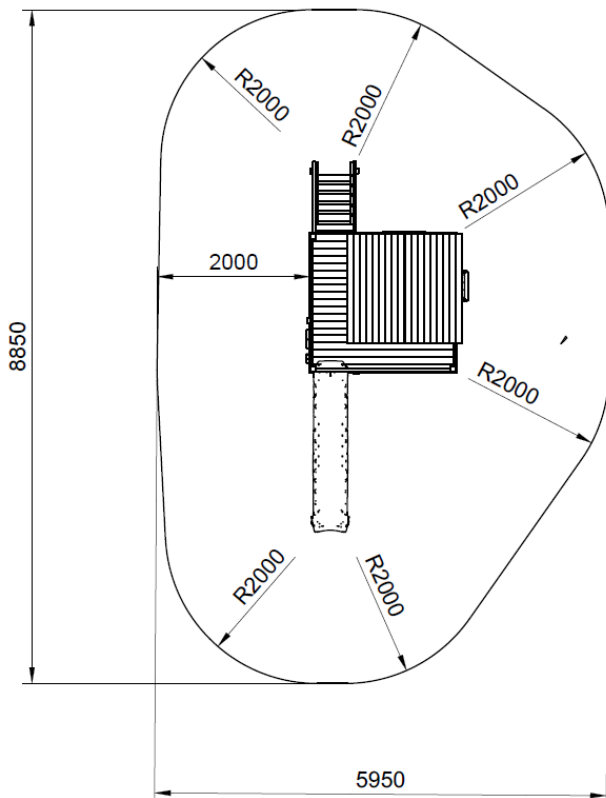
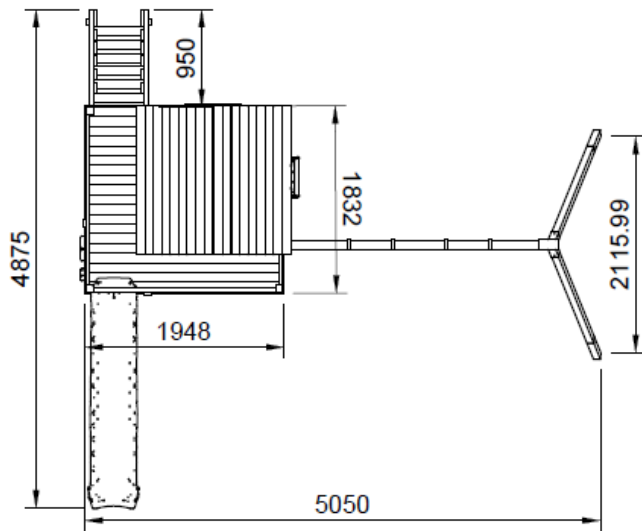
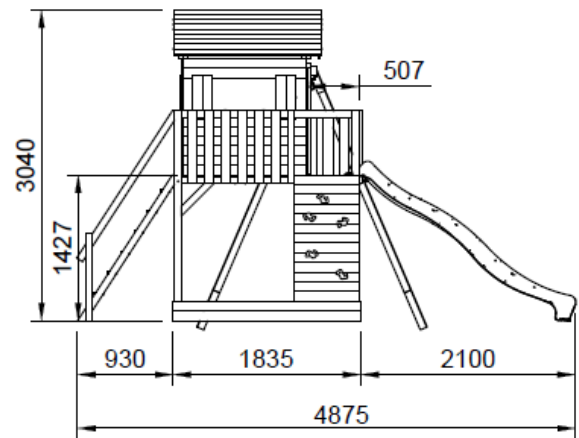
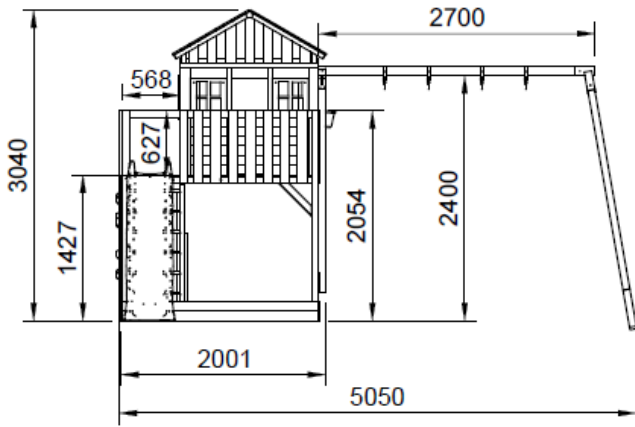

1



Advertencia
Warning
Attention
Aviso
Advertència

ESP Todas maderas cambian sus dimensiones según la humedad. Es muy recomendable dejar las maderas entre dos y tres días para que se sequen, las maderas pueden venir húmedas.

ENG All woods change their dimensions according to humidity. It is highly recommended to leave the wood between two and three days to dry, the wood can come wet.

FR Les bois changent de dimensions en fonction de l'humidité. Il est fortement recommandé de laisser le bois entre deux et trois jours afin qu'il s'adapte à l'humidité de son climat. De cette façon, il réduira les déformations par la suite.

PT Todas as madeiras mudam suas dimensões de acordo com a umidade. É altamente recomendável deixar a madeira entre dois e três dias para secar, a madeira pode ficar molhada.

IT Tutti i legni cambiano le loro dimensioni in base all'umidità. Si consiglia vivamente di lasciare asciugare il legno tra due e tre giorni, il legno può bagnarsi.

CAT Totes fustes canvien les dimensions segons la humitat. És molt recomanable deixar les fustes entre dos i tres dies perquè s'assequin, les fustes poden venir humides.

2



Advertencia
Warning
Attention
Aviso
Advertència

ESP Es necesario pretaladrar todas las maderas con una broca inferior al diámetro del tronillo para evitar roturas.

ENG All woods must be pre-drilled with a bit smaller than the screw to avoid critical cracks.

FR Tout le bois doit être pré-percé avec un foret plus petit que la vis pour éviter la casse.

PT Toda a madeira deve ser pré-perfurada com uma broca menor que o parafuso para evitar rupturas.

CAT Cal pre-foradar totes les fustes amb una broca de diàmetre inferior que el del cargol per evitar trencaments.

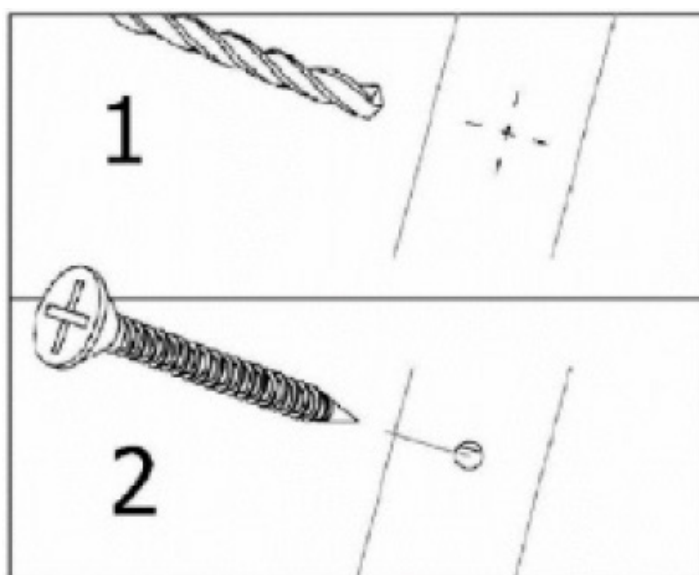
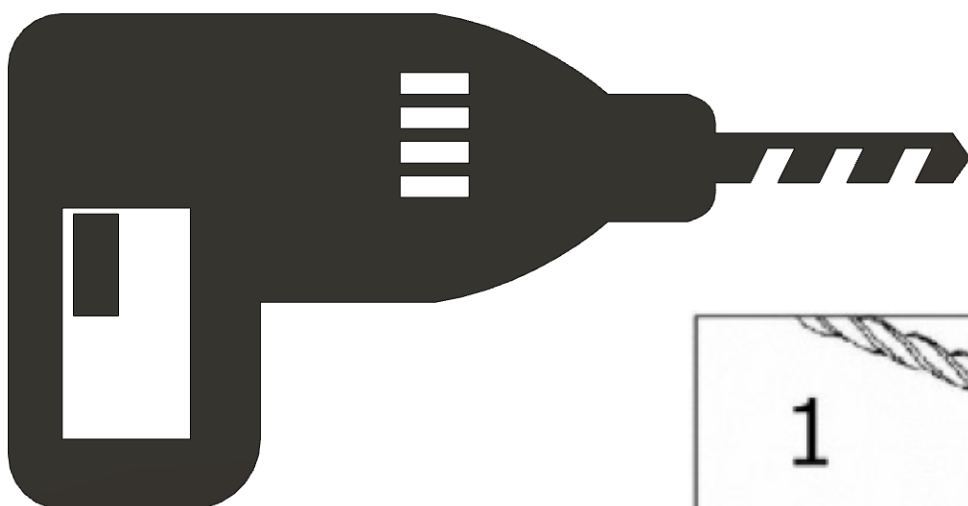

3



Advertencia
Warning
Attention
Aviso
Advertència

ESP En algunos casos es necesario esconder la cabeza de los tornillos. Para ello, taladre con una broca de entre Ø20 y Ø24, profundidad de 10 mm.

ENG In some cases it is necessary to hide the head of the screws and bolts. To do this, drill with a drill bit between Ø20 and Ø24, depth 10 mm.

FR Dans certains cas, il est nécessaire de cacher la tête des vis. Pour cela, percez avec un foret entre Ø20 et Ø24, profondeur 10 mm.



PT Em alguns casos é necessário esconder a cabeça dos parafusos. Para isso, fure com uma broca entre Ø20 e Ø24, profundidade 10 mm.

IT In alcuni casi è necessario nascondere la testa delle viti. Per fare ciò forare con una punta da Ø20 a Ø24, profondità 10 mm.

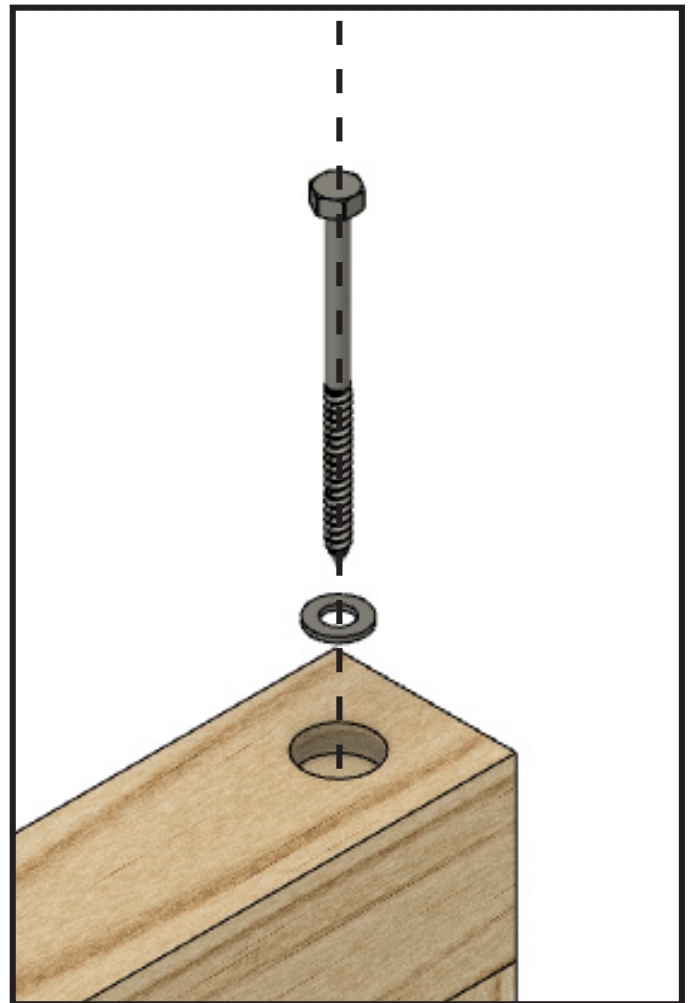

CAT En alguns casos és necessari amagar les cabotes dels cargols. Per fer-ho, cal foradar amb una broca d'entre Ø20 i Ø24, profunditat de 10 mm.





ES Leyenda

Forma	Ejemplo	Lectura
Letra "L" + "LETRA"	LA	Pieza A de la casita Lollipop XL.
Letra "T" + "LETRA"	TA	Pieza A de la estructura de la torre.
Letra "G" + "LETRA"	GA	Pieza A del conector con el columpio.
Doble "LETRA"	AA	Pieza construida o elemento de no madera.
"Letra"	a	Elemento de tornilleria.
"LETRAS" dentro de un circulo con trazado continuo		Identificador de la pieza de madera en el paso.
"Letra" dentro de un circulo con trazado discontinuo		Identificador de elemento de tornilleria en el paso.



ENG Caption

Forma	Ejemplo	Lectura
Letter "L" + "LETRA"	LA	Part A of the Lollipop XL.
Letter "T" + "LETRA"	TA	Part A of the tower structure.
Letter "G" + "LETRA"	GA	Part A of the connector of the swing.
Doble "LETTER"	AA	Constructed piece or non-wood element.
"Letter"	a	Screw element.
"LETRAS" within a continuous circle		Identifier of the piece of wood in the step.
"Letras" within a dotted circle		Identifier of the piece of screw element in the step.

FR Légende

Forma	Ejemplo	Lectura
Lettre "L" + "LETTRE"	LA	Partie A de la maison Lollipop.
Lettre "T" + "LETTRE"	TA	Partie A de la structure de la tour.
Lettre "G" + "LETTRE"	GA	Partie A du connecteur de la balançoire.
Double "LETTRE"	AA	Pièce construite ou élément non en bois.
"Lettre"	a	Élément à vis.
"LETTRE" dans un cercle avec une ligne brisée		Identifiant du morceau de bois dans l'étape.
"Letras" within a dotted circle		Identificateur d'élément matériel dans l'étape.

CAT Llegenda

Forma	Ejemplo	Lectura
Lletra "L" + "LLETRA"	LA	Peça A de la Caseta Lollipop XL.
Lletra "T" + "LLETRA"	TA	Peça A de l'estructura de la Torre.
Lletra "G" + "LLETRA"	GA	Peça A de l'annex per connectar el gronxador.
Doble LLETRA	AA	Peça construida o de peça no de fusta en un pas.
Lletra minúscula	a	Element de fixació.
"LLETRES" dins d'un cercle de traçada continua		Identificador de peça en pas.
"Lletres" dins d'un cercle de traçada discontinua		Identificador d'element de fixació en pas.

1.1

- X2 - TA
- X1 - TB
- X2 - TR
- X1 - DD
- X8 - b
- X2 - k
- X2 - q
- X4 - s
- X2 - v

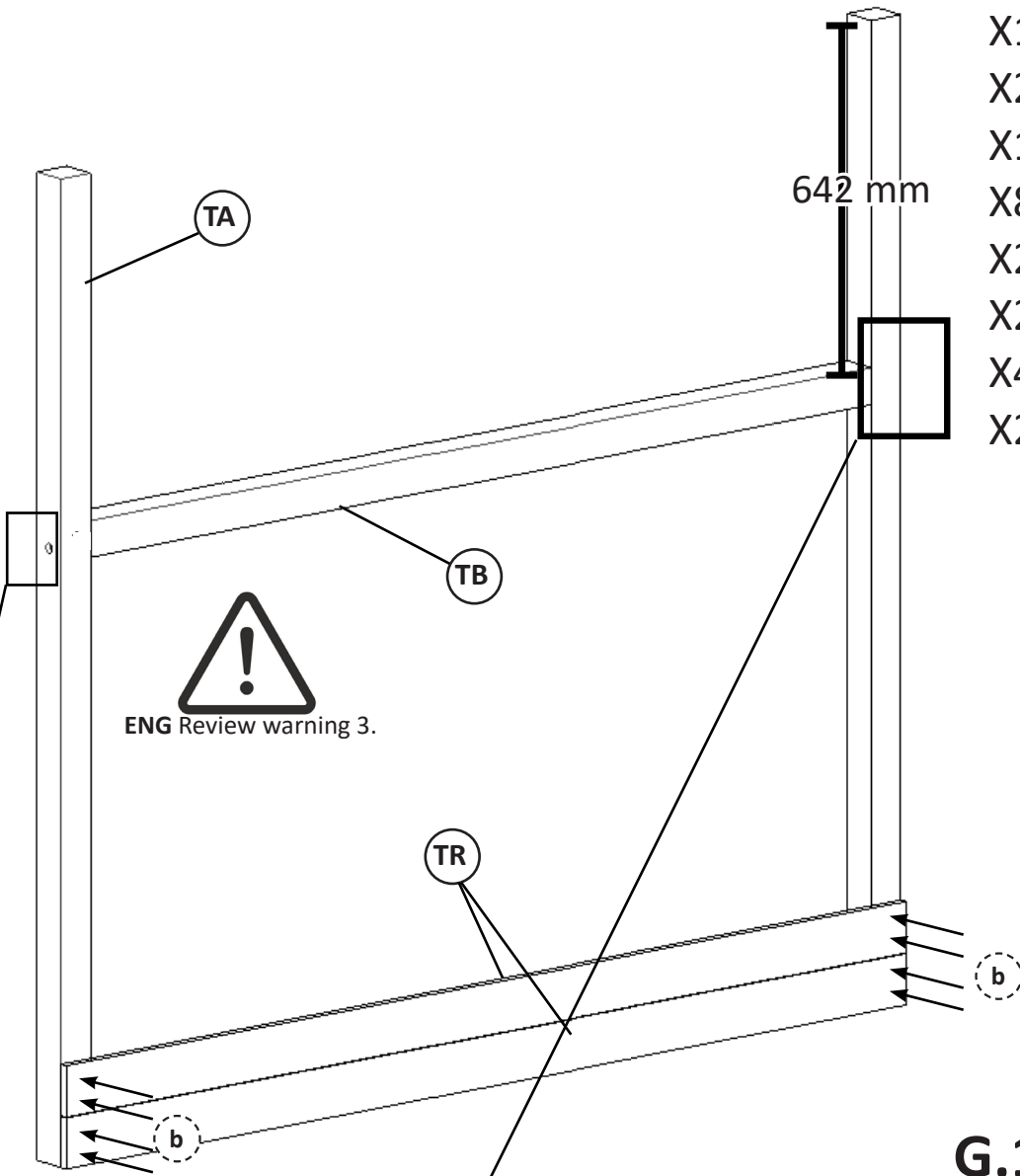

G.1

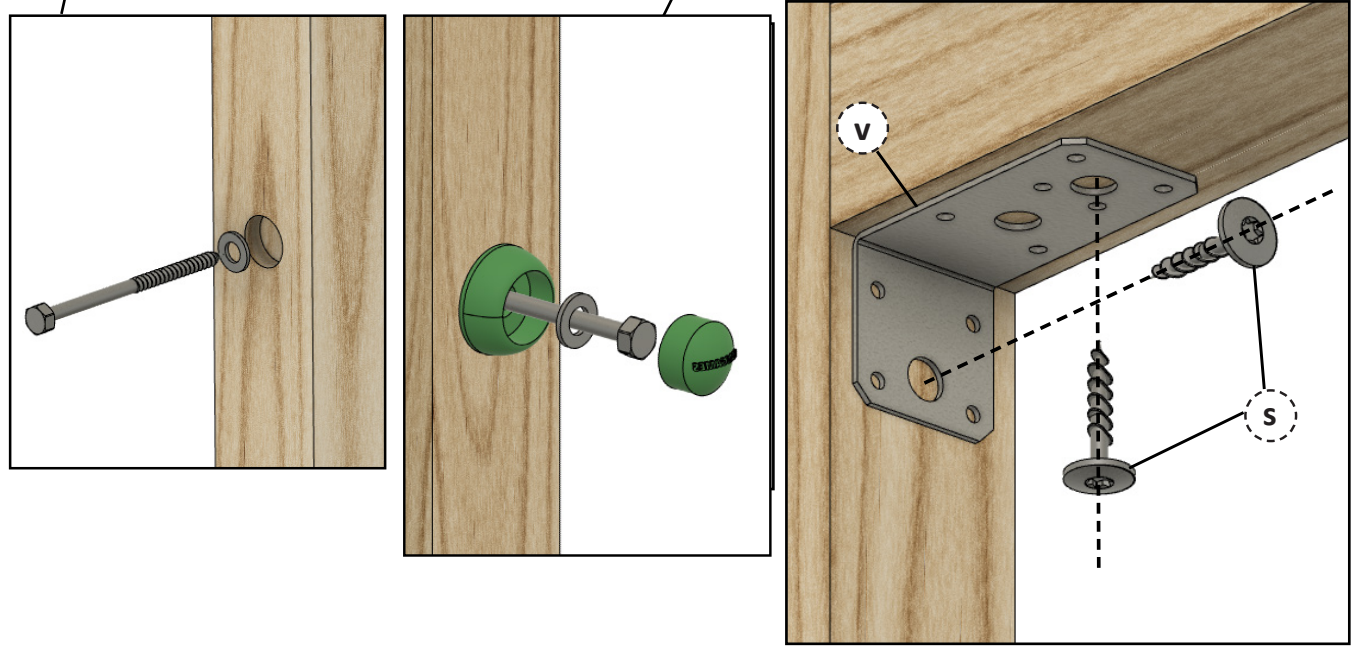

1.2

- X2 - TA
- X1 - TB
- X2 - TR
- X2 - DD
- X8 - b
- X2 - k
- X2 - q
- X4 - s
- X2 - v

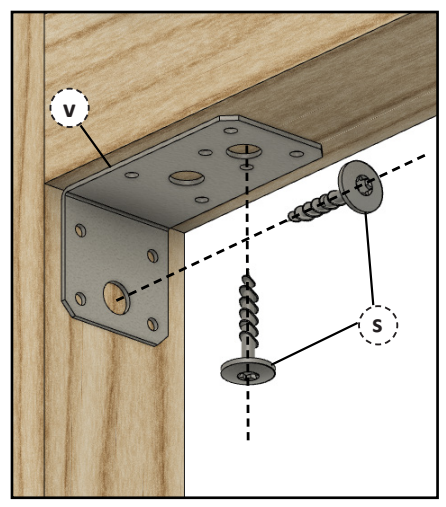
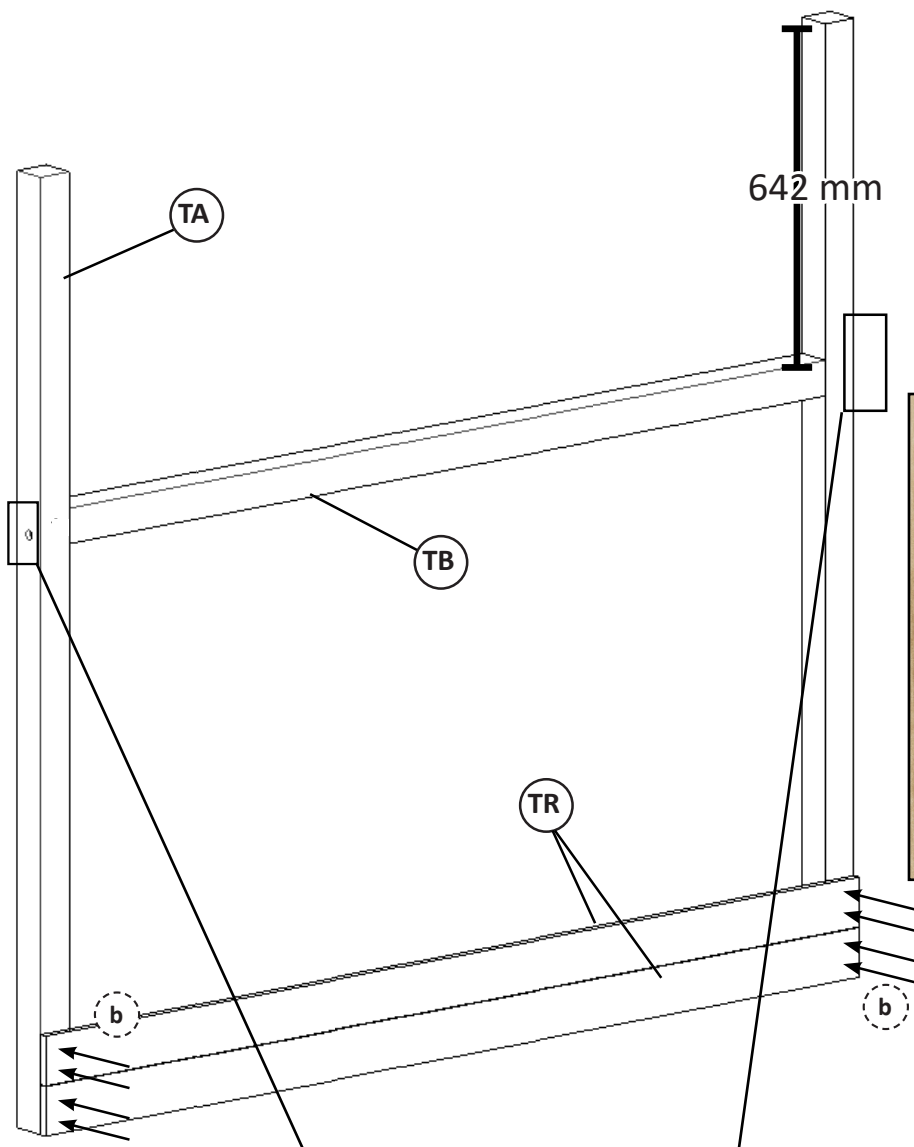

G.2

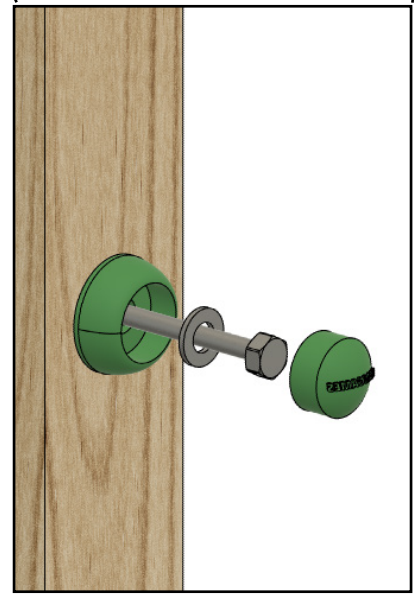

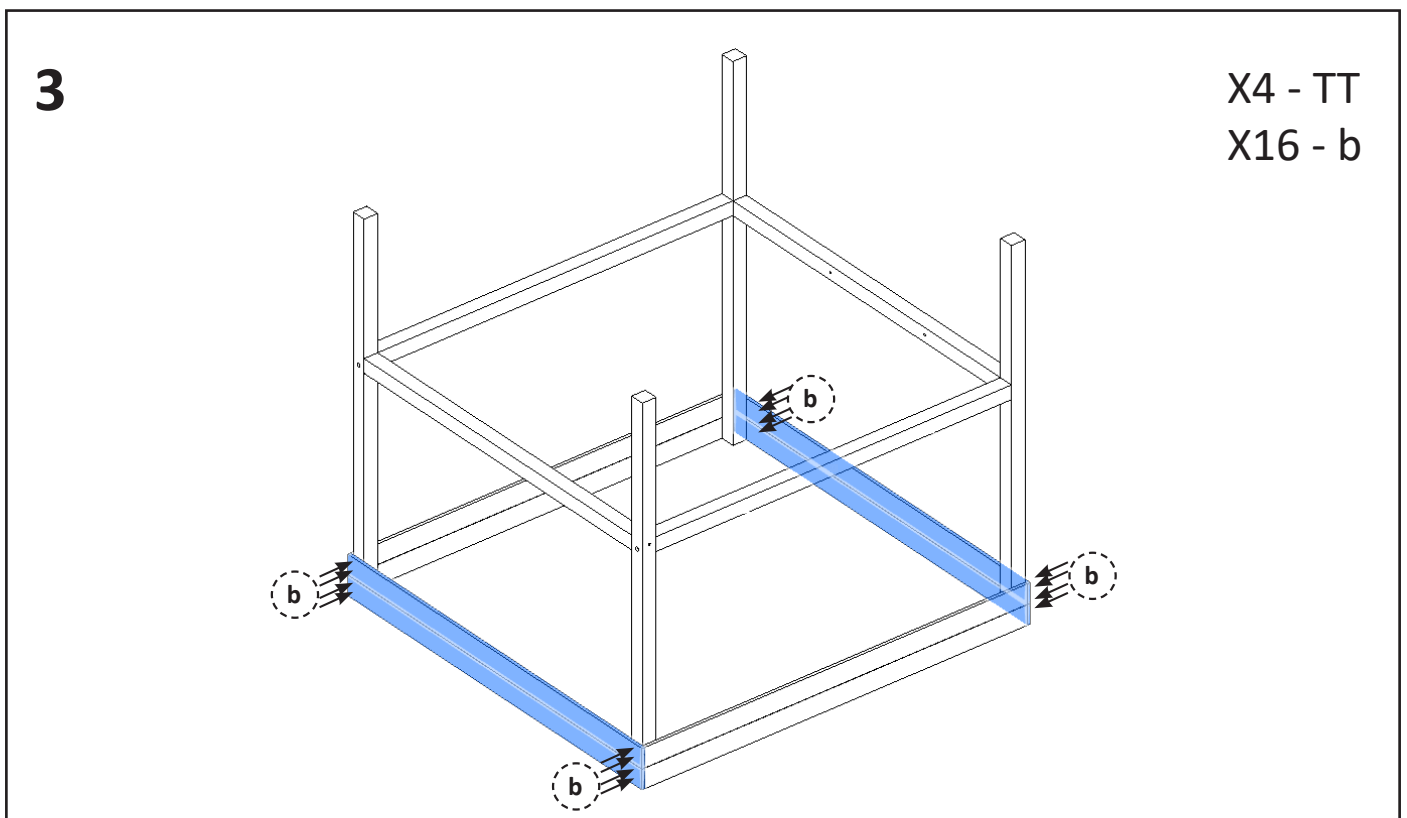
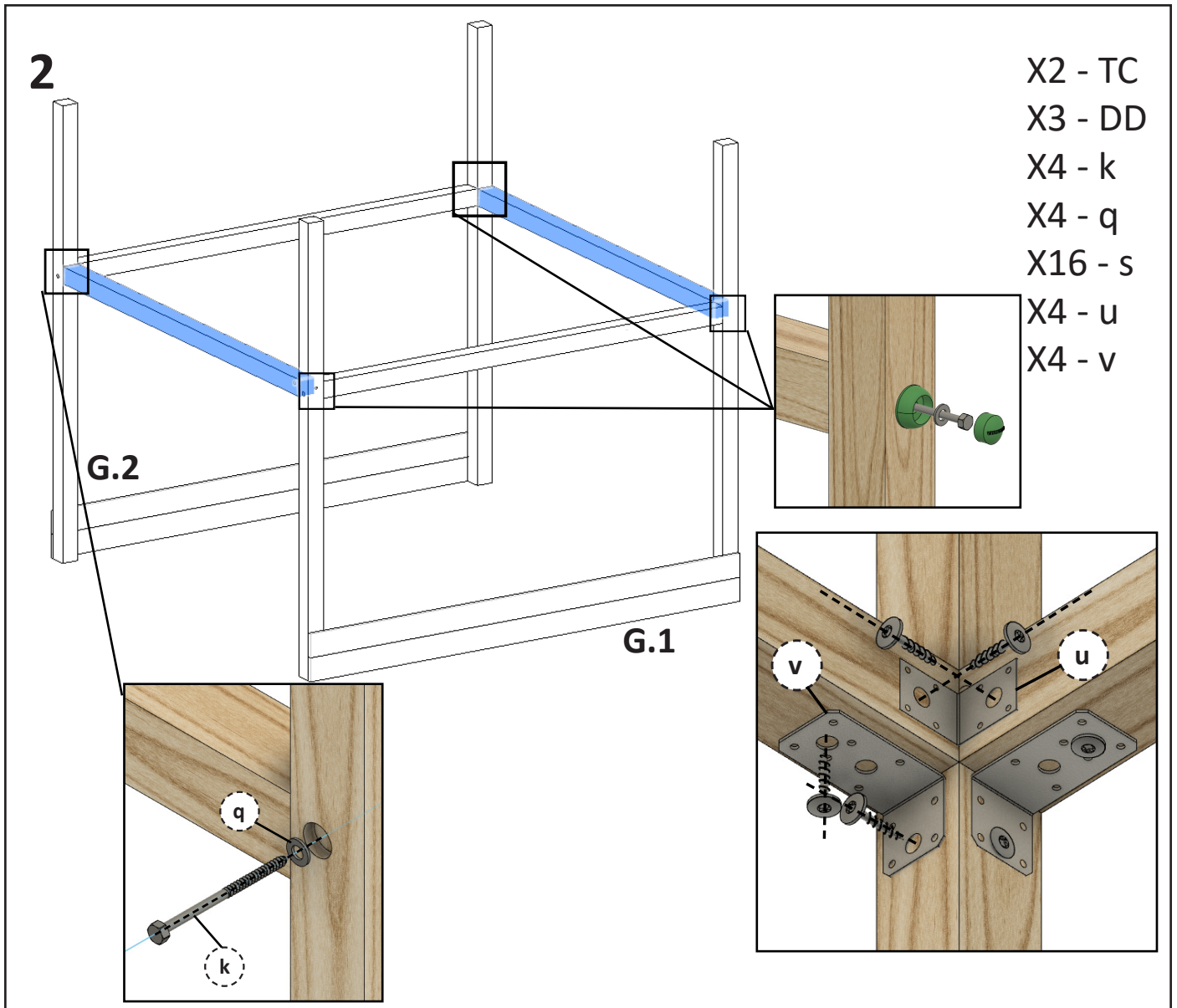

4.1

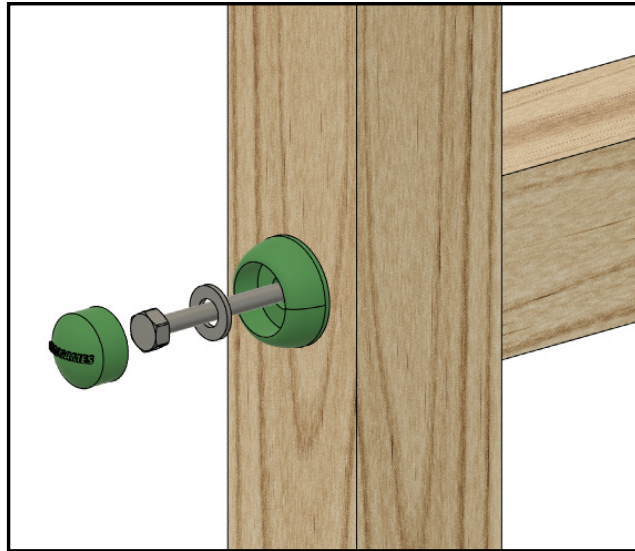

X3 - TC
X3 - DD
X6 - k
X6 - q

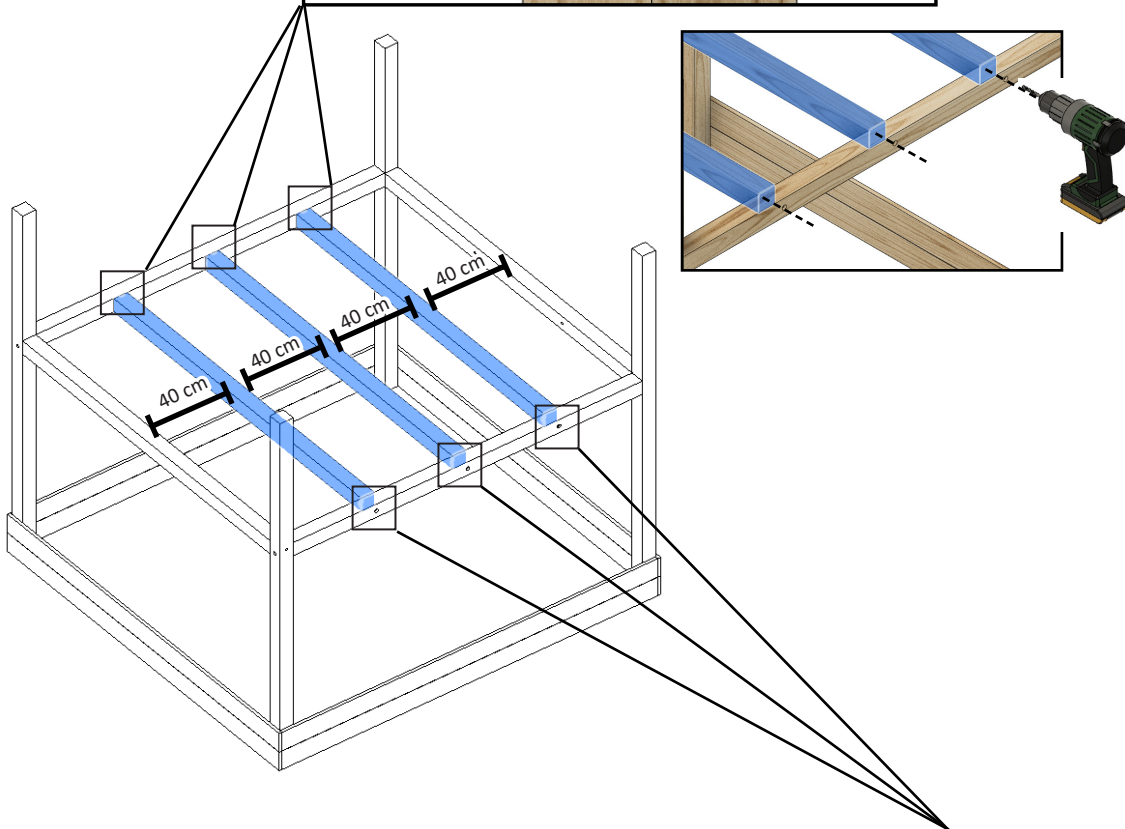

ESP Revise la advertència 3.
ENG Review warning 3.
FR Revoir l'avertissement 3.
PT Revise o aviso 3.
CAT Revisi l'advertència 3.

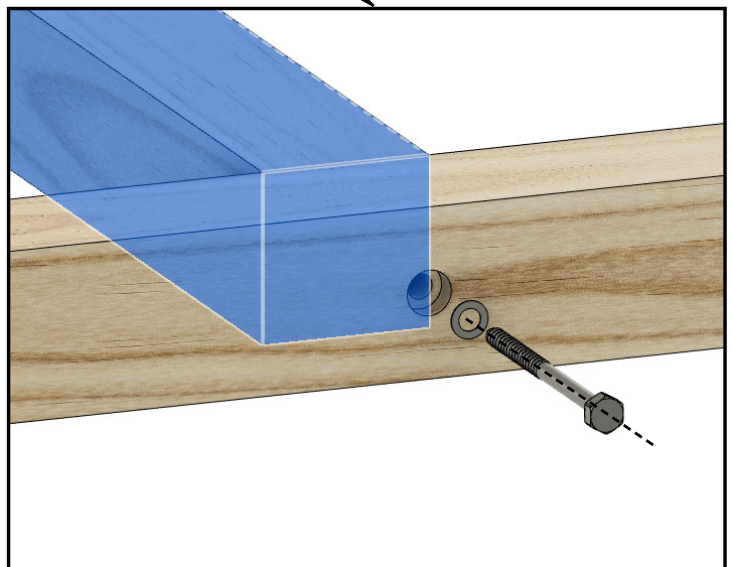

4.2

X24 - s
X12 - v

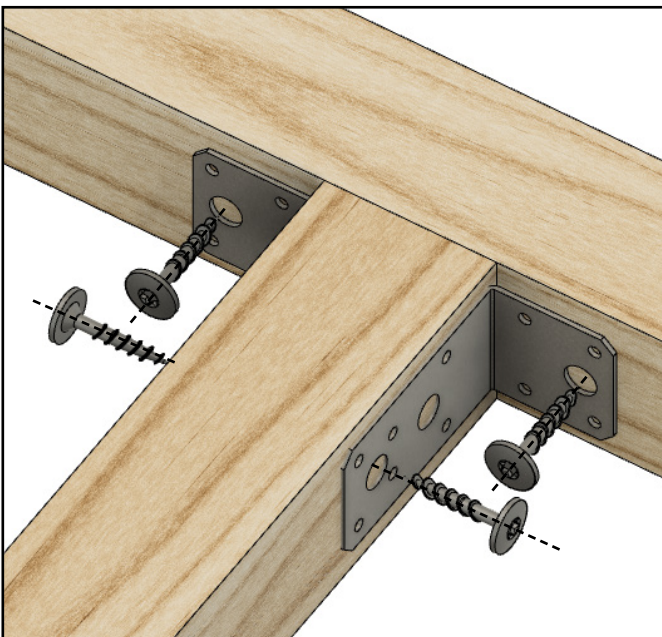
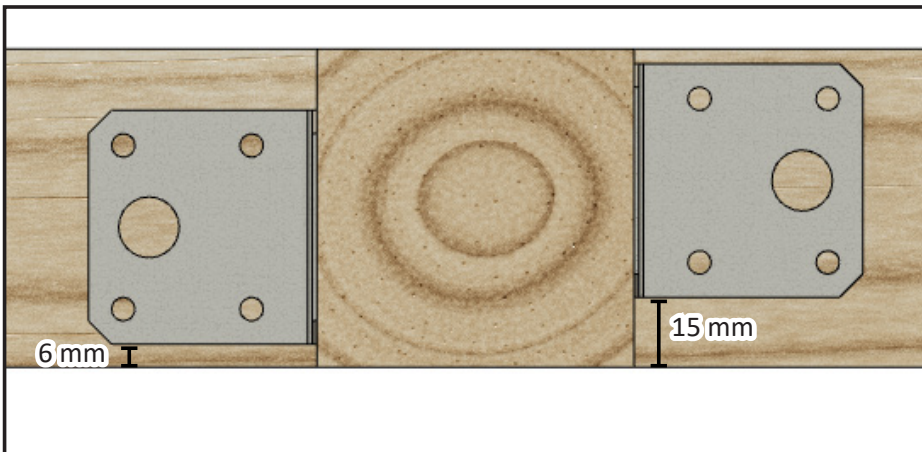
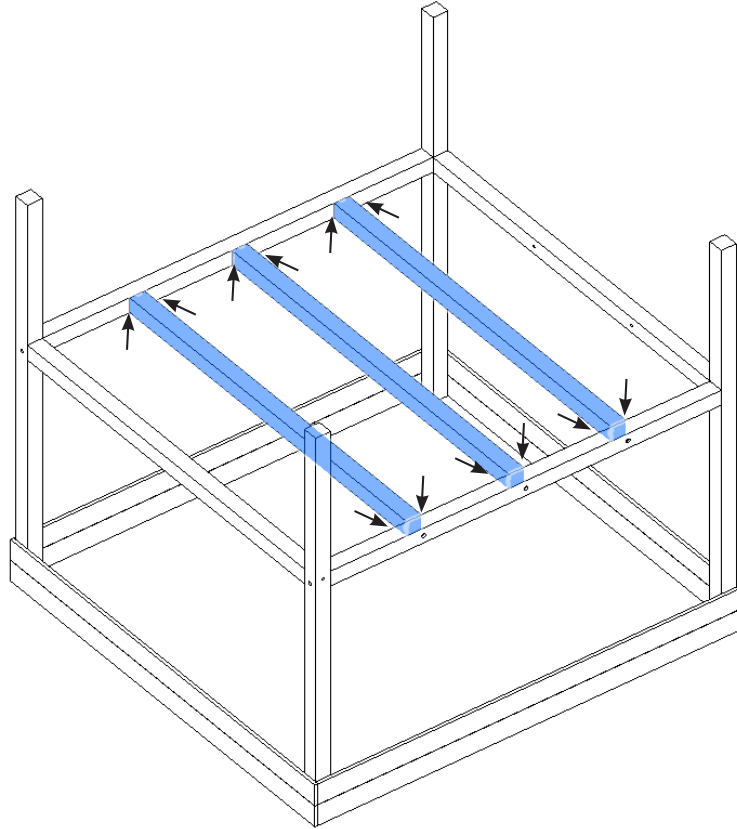

ESP Coloque las escuadras a diferentes alturas para evitar el contacto de tornillos

ENG Place the squares at different heights to avoid screw contact

FR Placez les équerres à différentes hauteurs pour éviter le contact des vis

PT Coloque as esquadrias em alturas diferentes para evitar o contato dos parafusos

CAT Col·loqui les esquadres a diferents alçades per evitar el contacte dels cargols.

5

X1 - TD
X4 - b
X2 - e

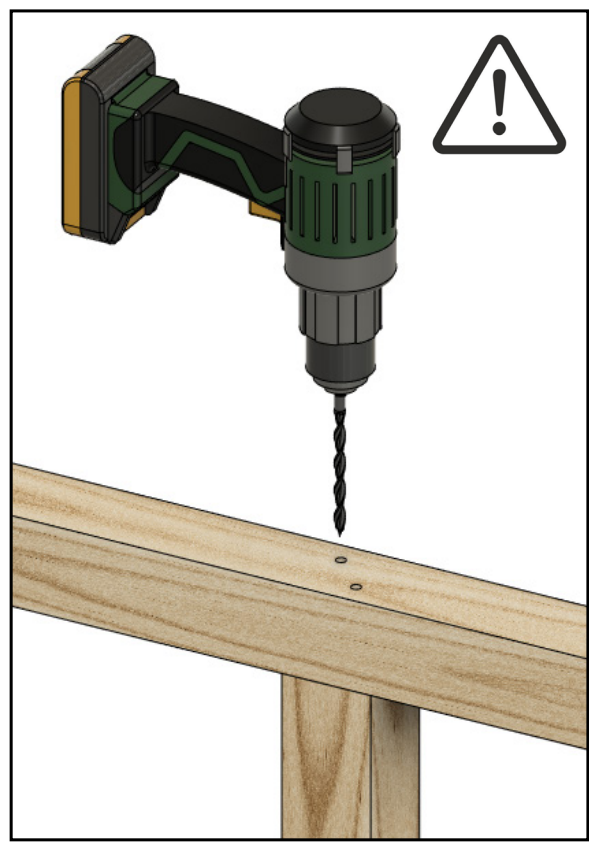
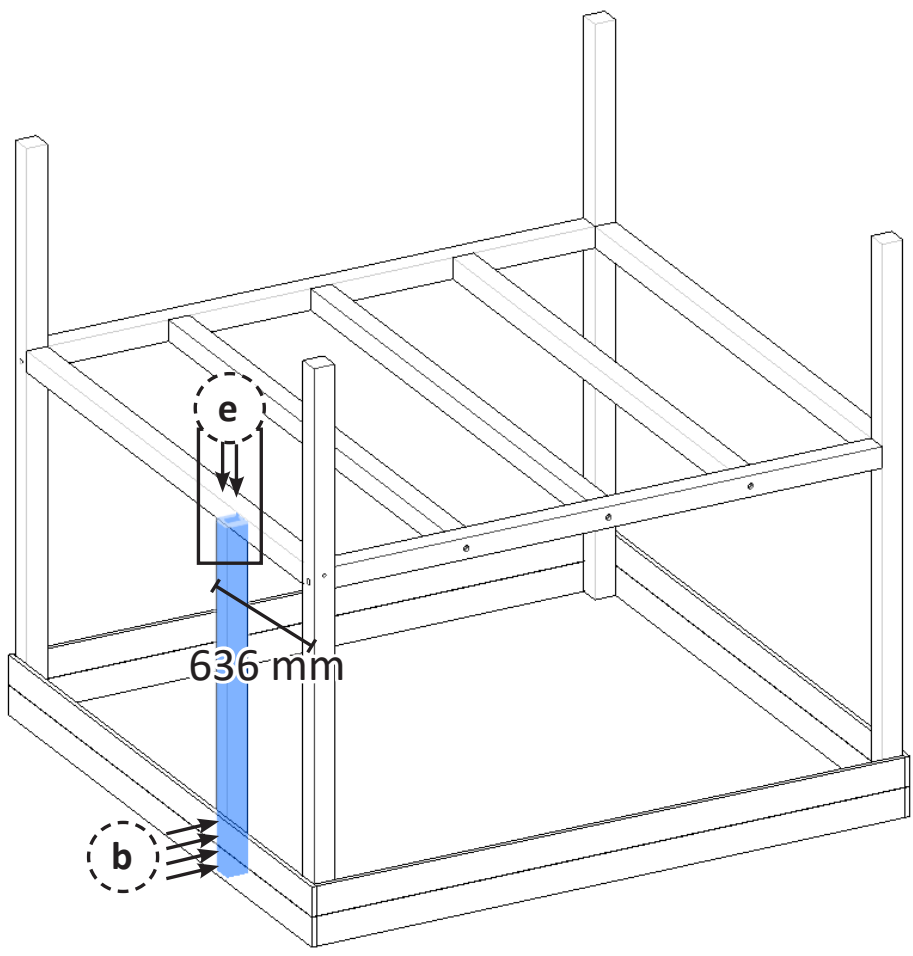

6a

X8

X8 - F



ESP Perforen las maderas perpendicularmente al plano inclinado.

ENG Drill the wood perpendicular to the sloping plane.

FR Percez le bois perpendiculairement au plan incliné.

PT Fure as madeiras perpendicularmente ao plano inclinado.

CAT Preforadeu les fustes perpendicularment al plà inclinat.



6b

X32 - f

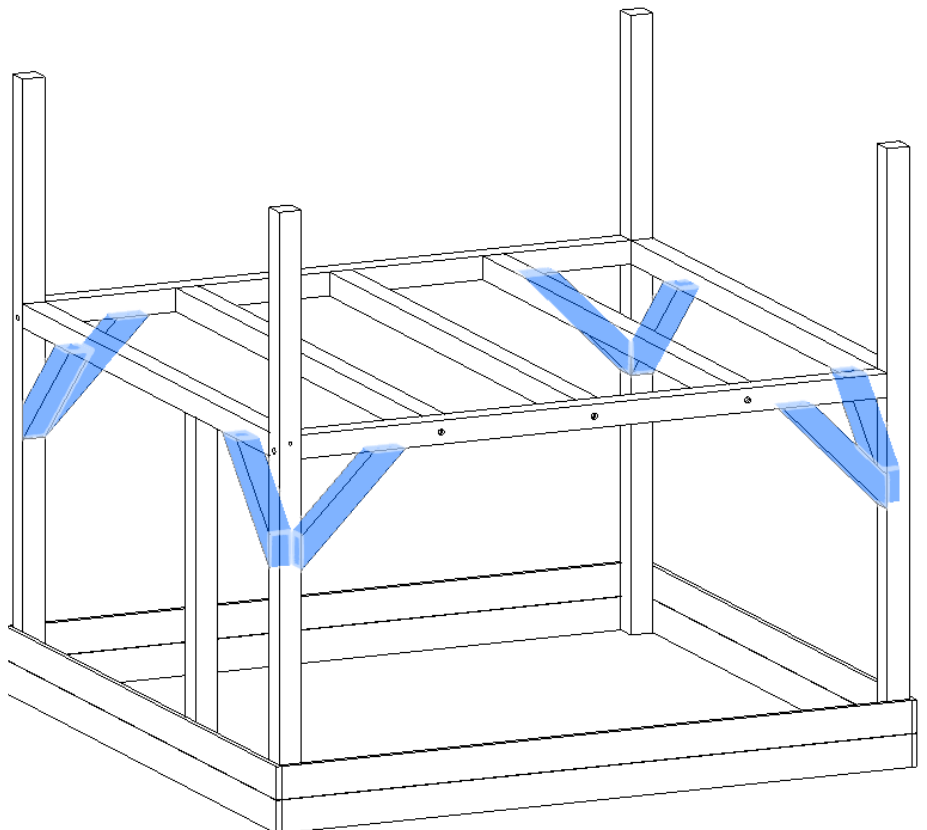
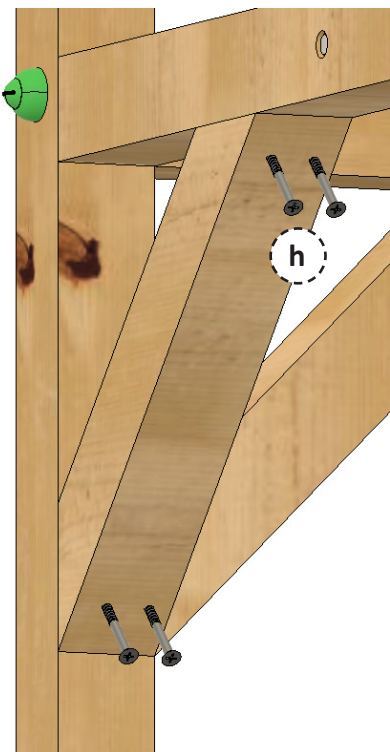

7

X2 - TS
X8 - b

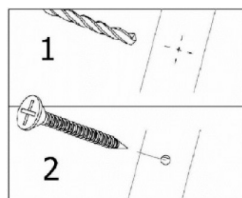
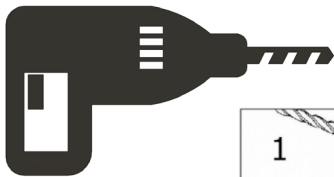
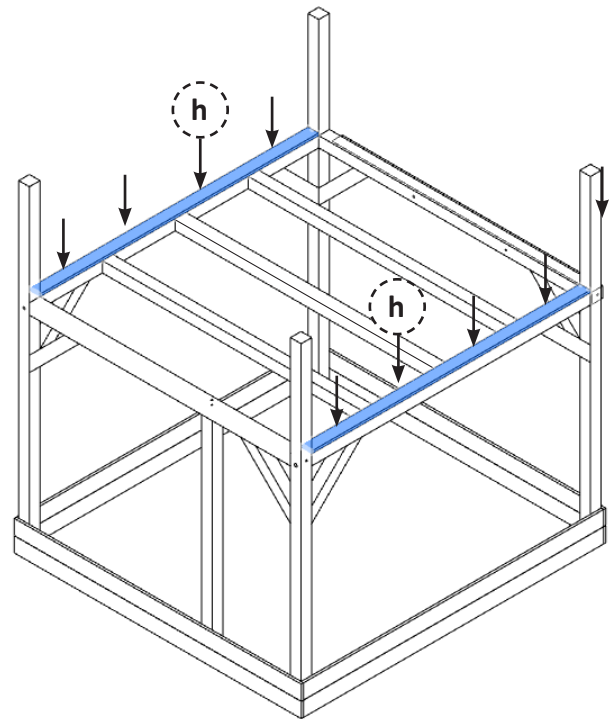
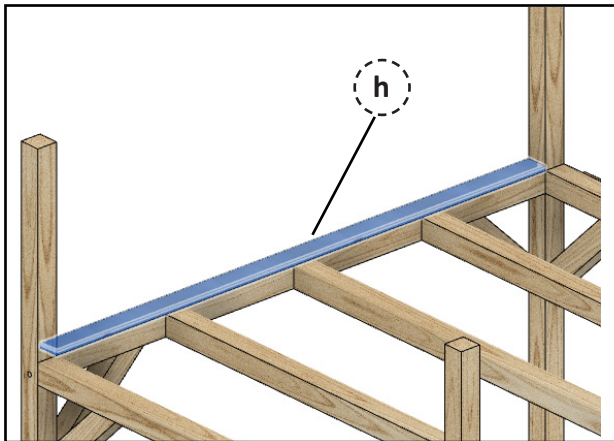

8a

ESP Colocad todas las maderas antes de atornillarlas.

ENG Place all woods before screwing.

FR Placer tous les bois avant de visser.

PT Coloque todas as madeiras antes de aparafusar.

CAT Col·loqueu totes les fustes abans de cargolar-les.

X16 - TR

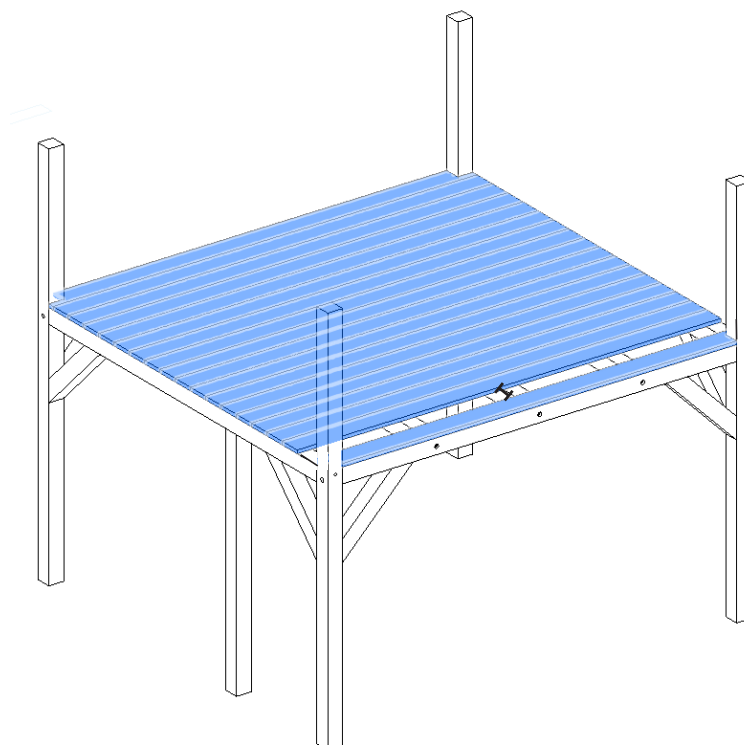

8b

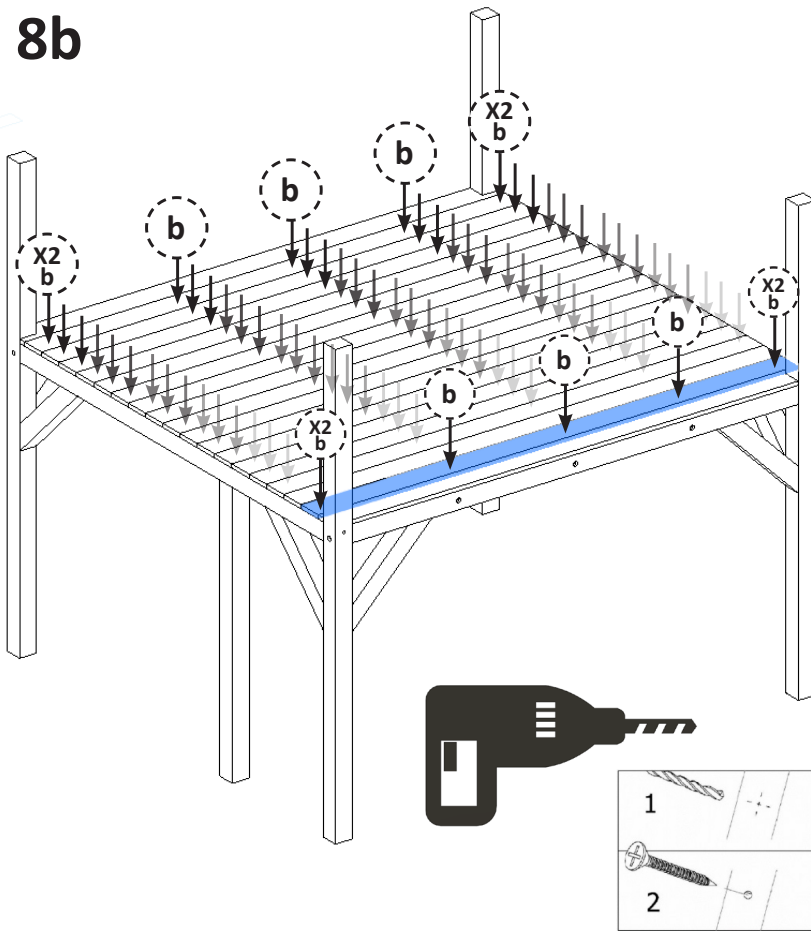

X1 - TR
X1 - TW
X119 - b

ESP La plataforma está diseñada para la sección nominal de 95 x 15 mm. La madera es un material vivo y este valor puede variar significativamente. Utilice la madeta TR o TW según conveniencia.

ENG The platform is designed for the nominal edge profile of 95 x 15 mm. Wood is a living material and this value can vary significantly. Use the TR or TW wood according to your convenience.

FR La plate-forme est conçue pour la section nominale de 95 x 15 mm. Le bois est un matériau vivant et cette valeur peut varier considérablement. Utilisez le bois TR ou TW selon votre convenance.

PT A plataforma foi projetada para a seção nominal de 95 x 15 mm. A madeira é um material vivo e este valor pode variar significativamente. Use a madeira TR ou TW de acordo com sua conveniência.

CAT La plataforma està dissenyada per la secció nominal de 95 x 15 mm. La fusta és un material viu i aquest valor pot variar significativament. Utilitzeu la fusta TR o TW segons convingui.

9

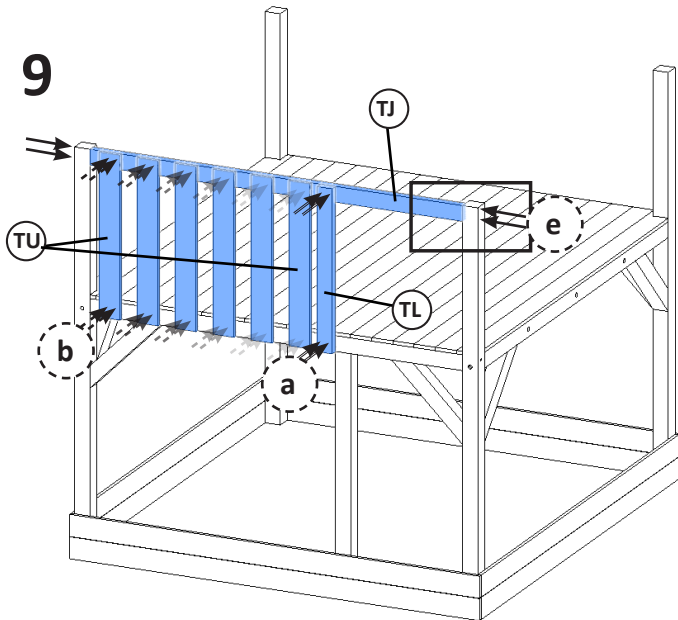

X1 - TJ
X1 - TL
X6 - TU
X4 - a
X24 - b
X4 - e

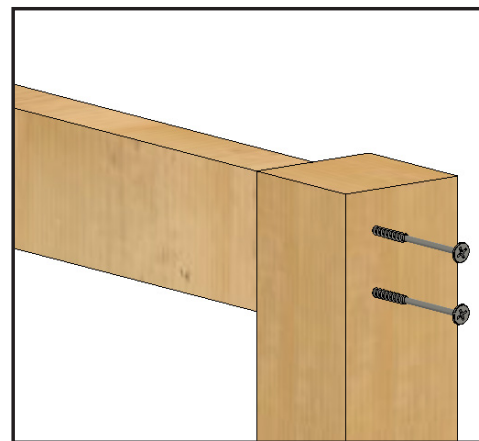

ESP Utilice el taco ZZ para colocar la barandilla

ENG Use the block ZZ to attach the railing.

FR Utilisez la prise ZZ pour fixer le garde-corps.

PT Use o bloco ZZ para prender o corrimão.

CAT Utilitzi el taco ZZ per col·locar la barana

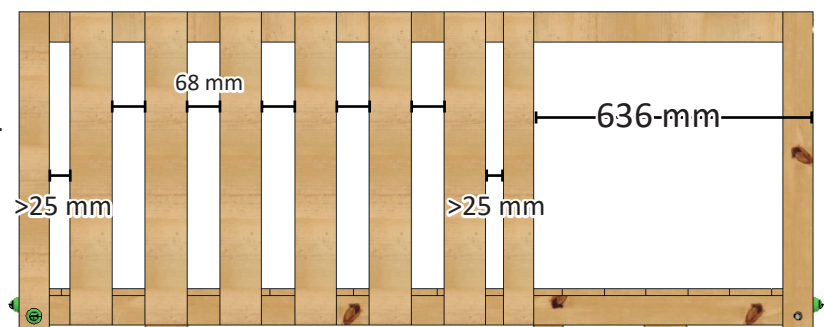

10

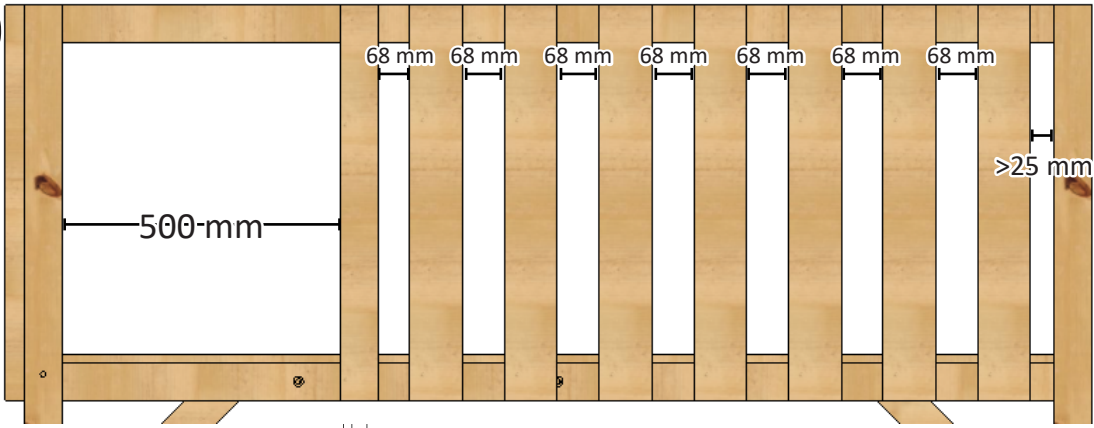

X1 - TG
 X1 - TL
 X6 - TU
 X4 - a
 X24 - b
 X4 - e

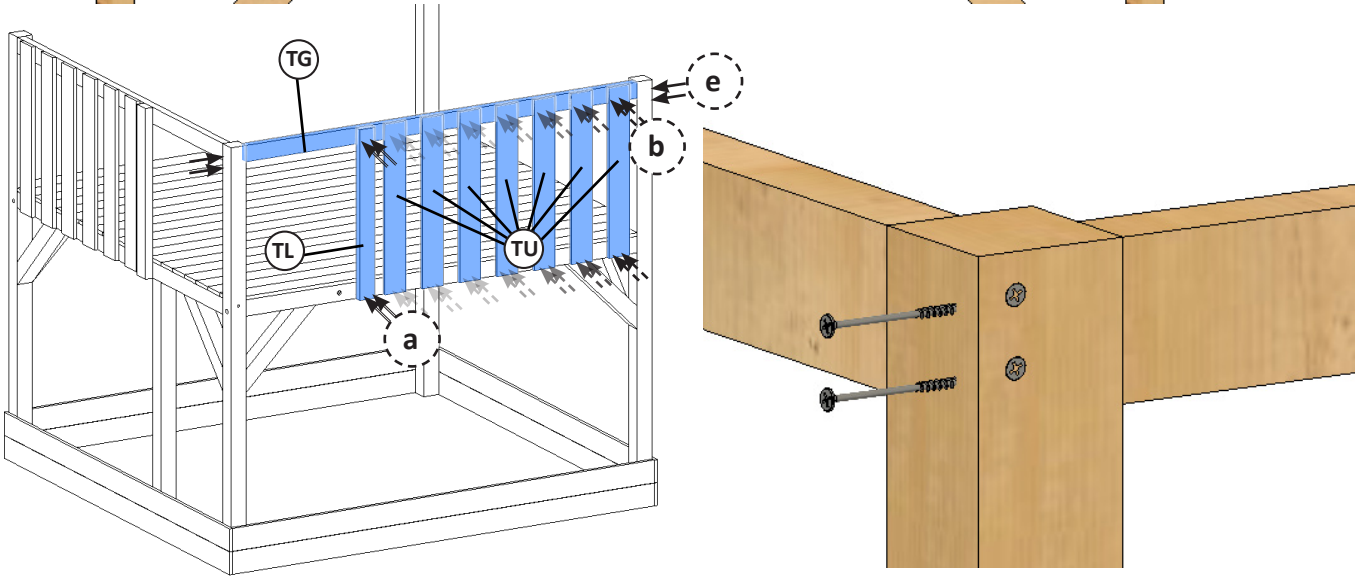

11

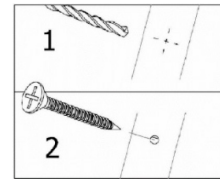
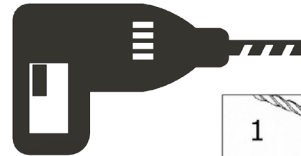
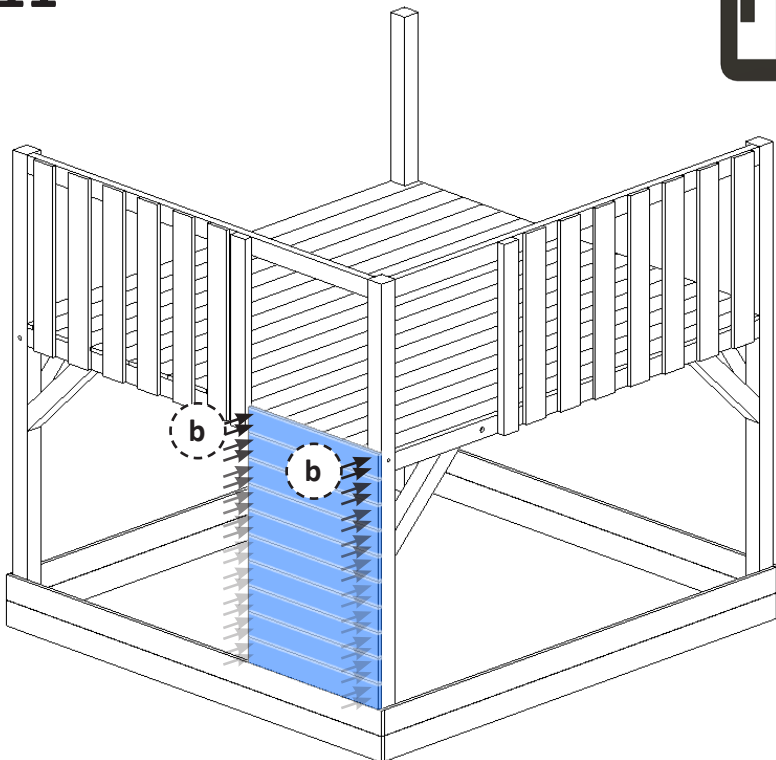

Parque L
 X10 - TV
 X40 - b
 Parque XL
 X13 - TV
 X52 - b

ESP Distribuya el espacio entre las maderas o, en caso que fuera necesario, corte una de las maderas centrales de la pared.

ENG Distribute the spaces between the boards or, if necessary, cut one of the central boards of the wall.

FRA Répartissez les espaces entre les planches ou, si nécessaire, découpez une des planches centrales du mur.

PT Distribua os espaços entre as madeiras ou, se precisa, cortar uma das madeiras centrais da parede.

CAT Distribueixi l'espai entre les fustes o, en cas que sigui necessari, talli una de les fustes centrals de la paret.

12

X5 - CC

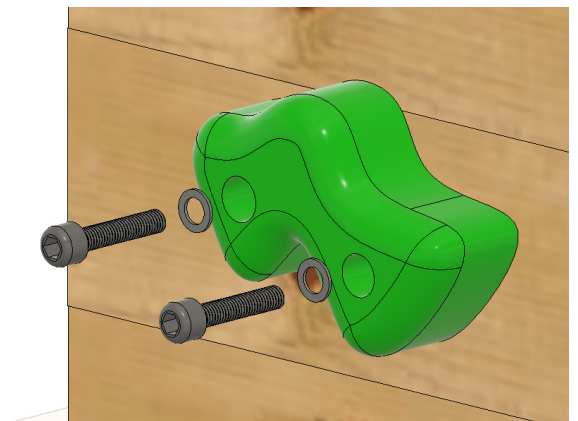
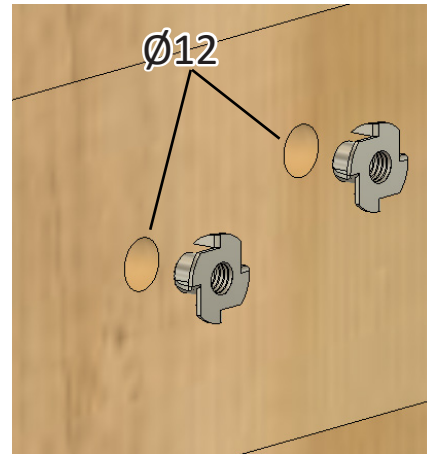
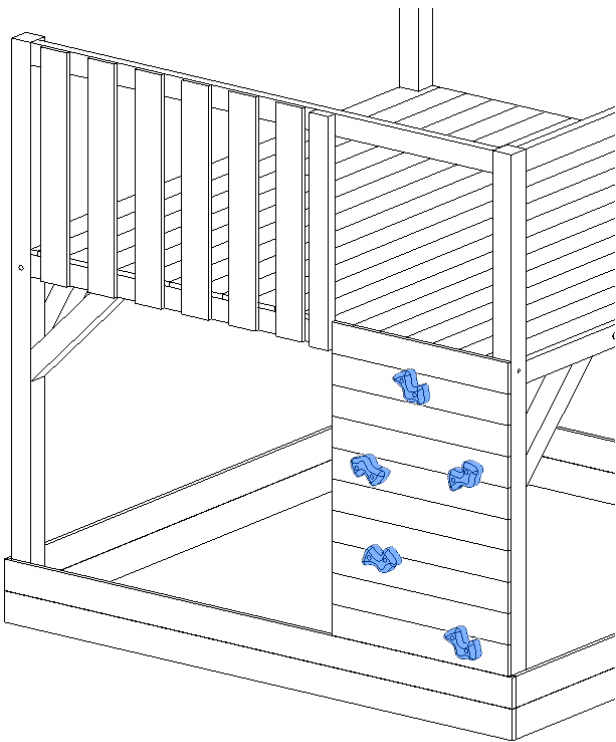

13

X4 - LB
X12 - LG
X48 - b

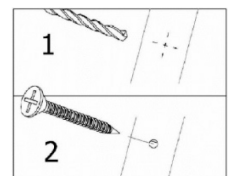
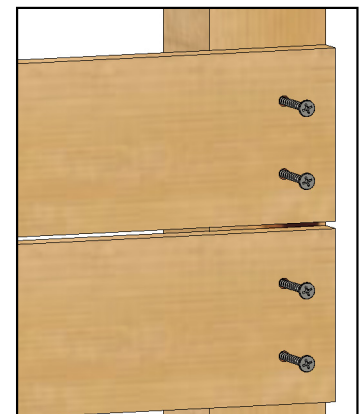
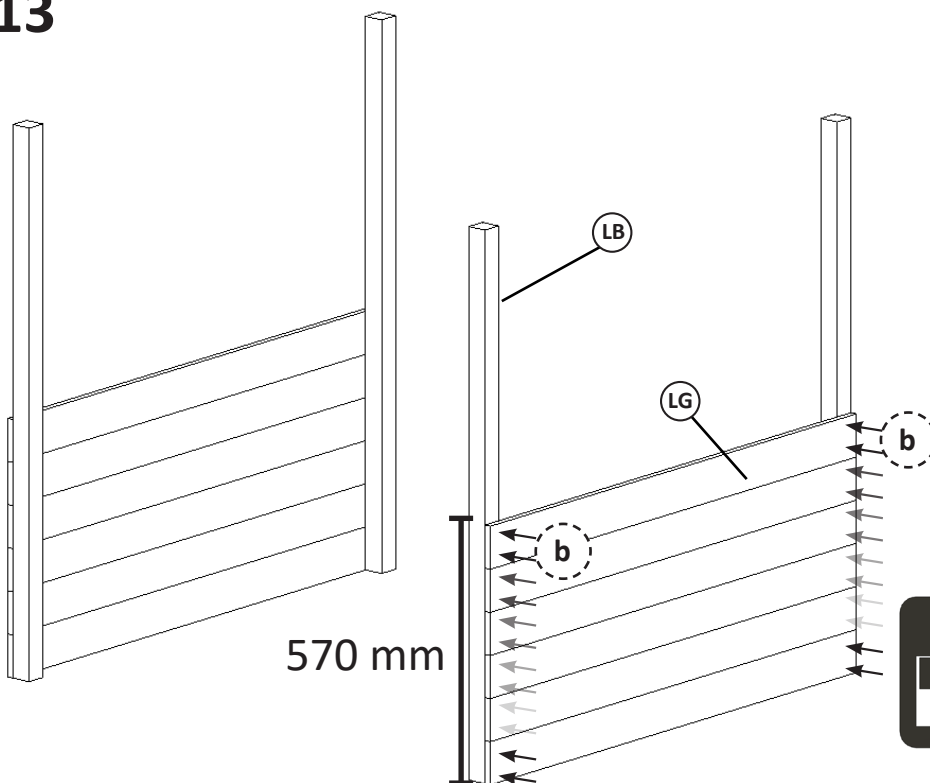

14

X6 - LF
X24 - b

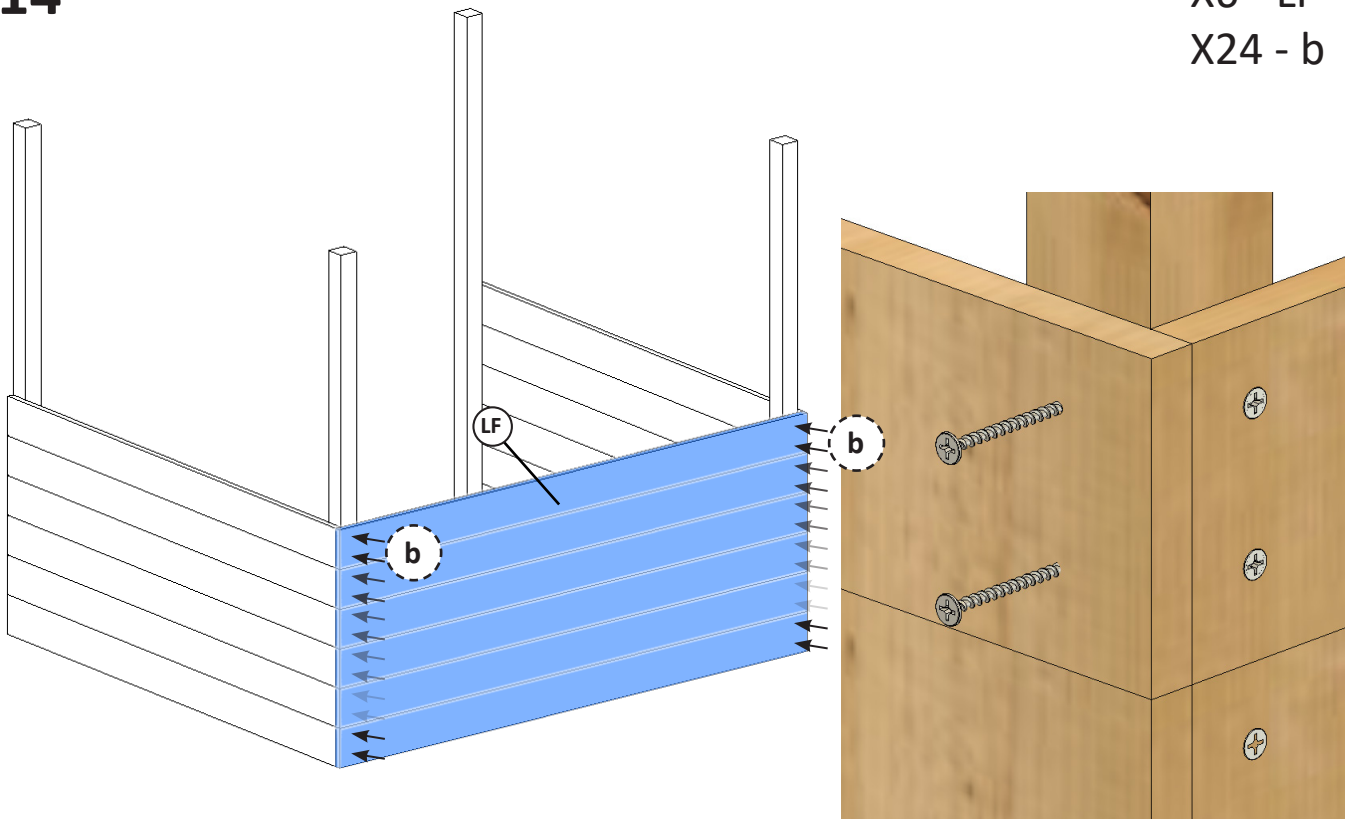

ESP Construya el paso 13 directamente en la plataforma.

ENG Assemble step 13 directly onto the platform.

FRA Construisez l'étape 13 directement sur la plateforme.

PT Construa a etapa 13 diretamente na plataforma.

CAT Construeixi el pas 13 directament sobre la plataforma.

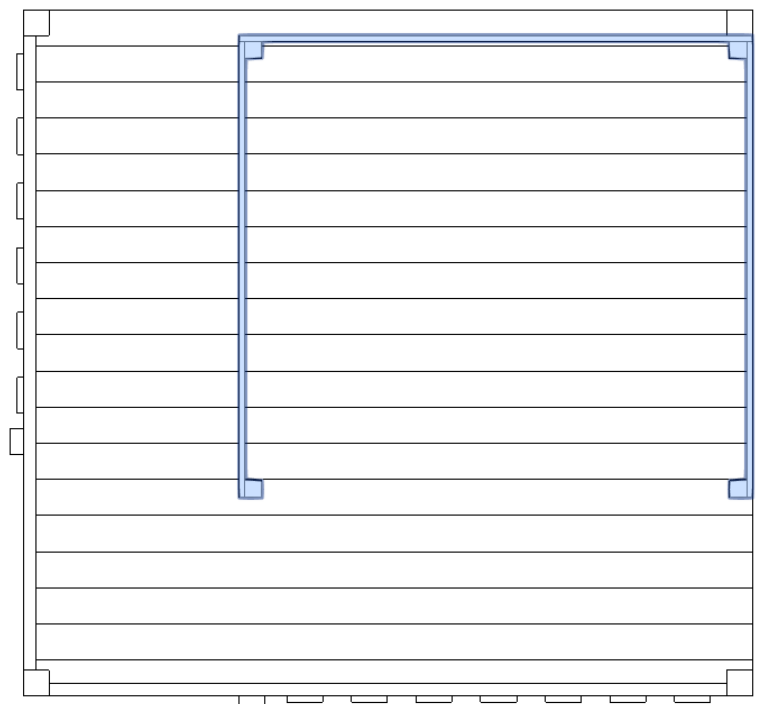
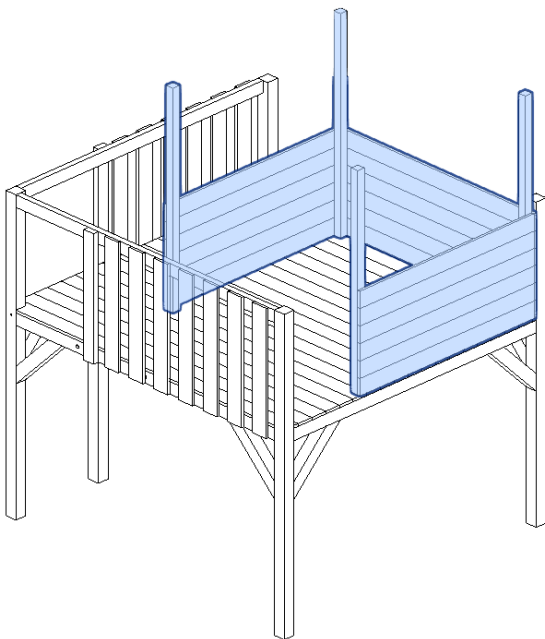

15

X1 - TE
X6 - e

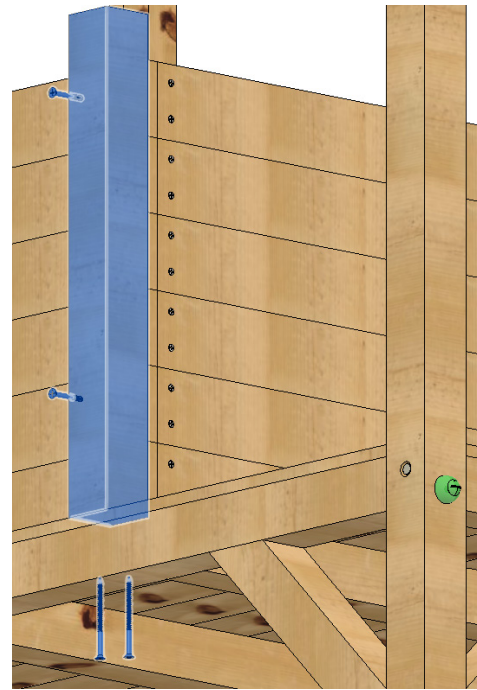
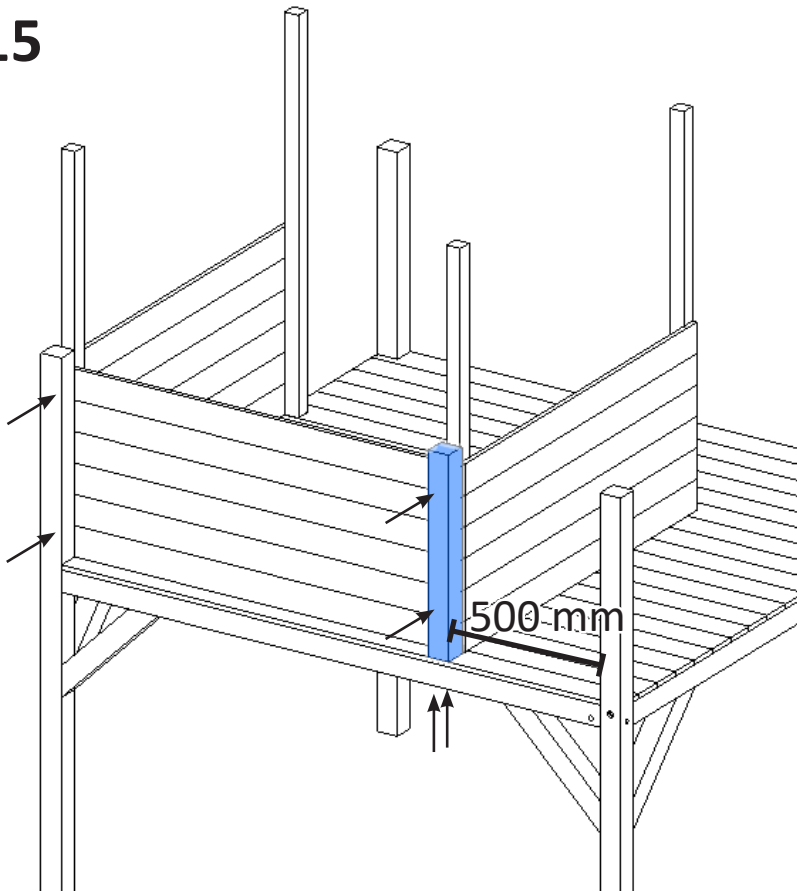

16

X2 - LI
X10 - b

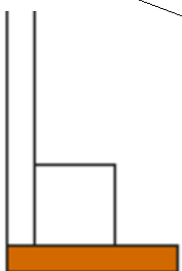
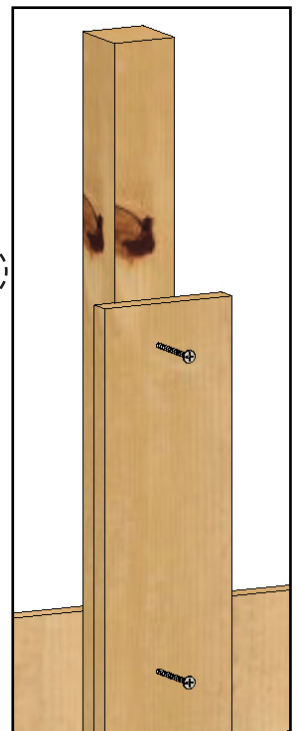
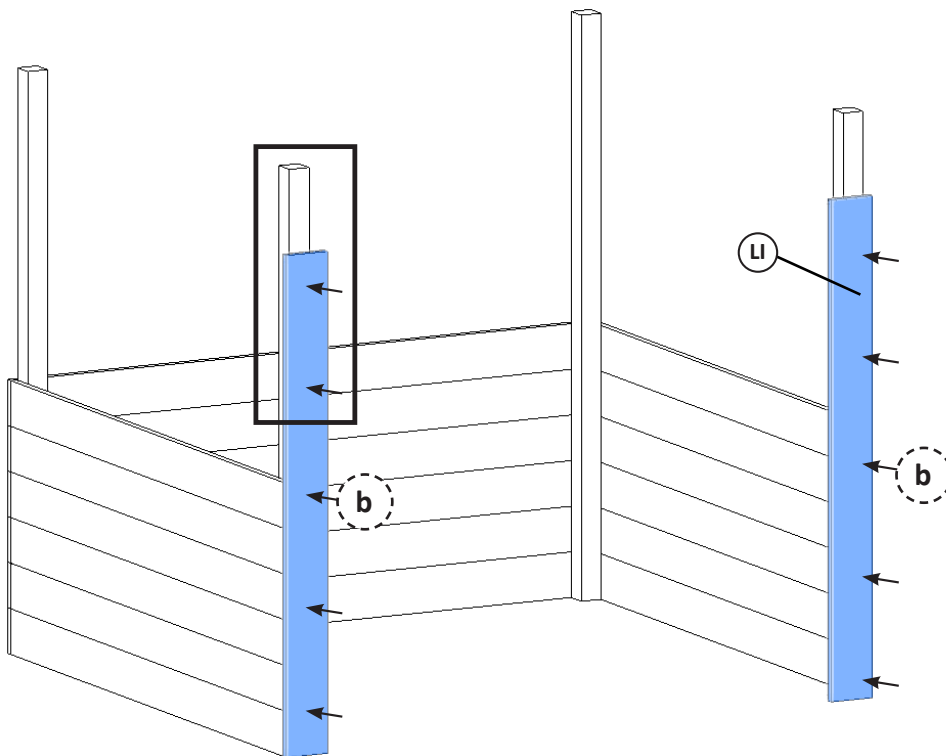

17

X4 - LI
X10 - c

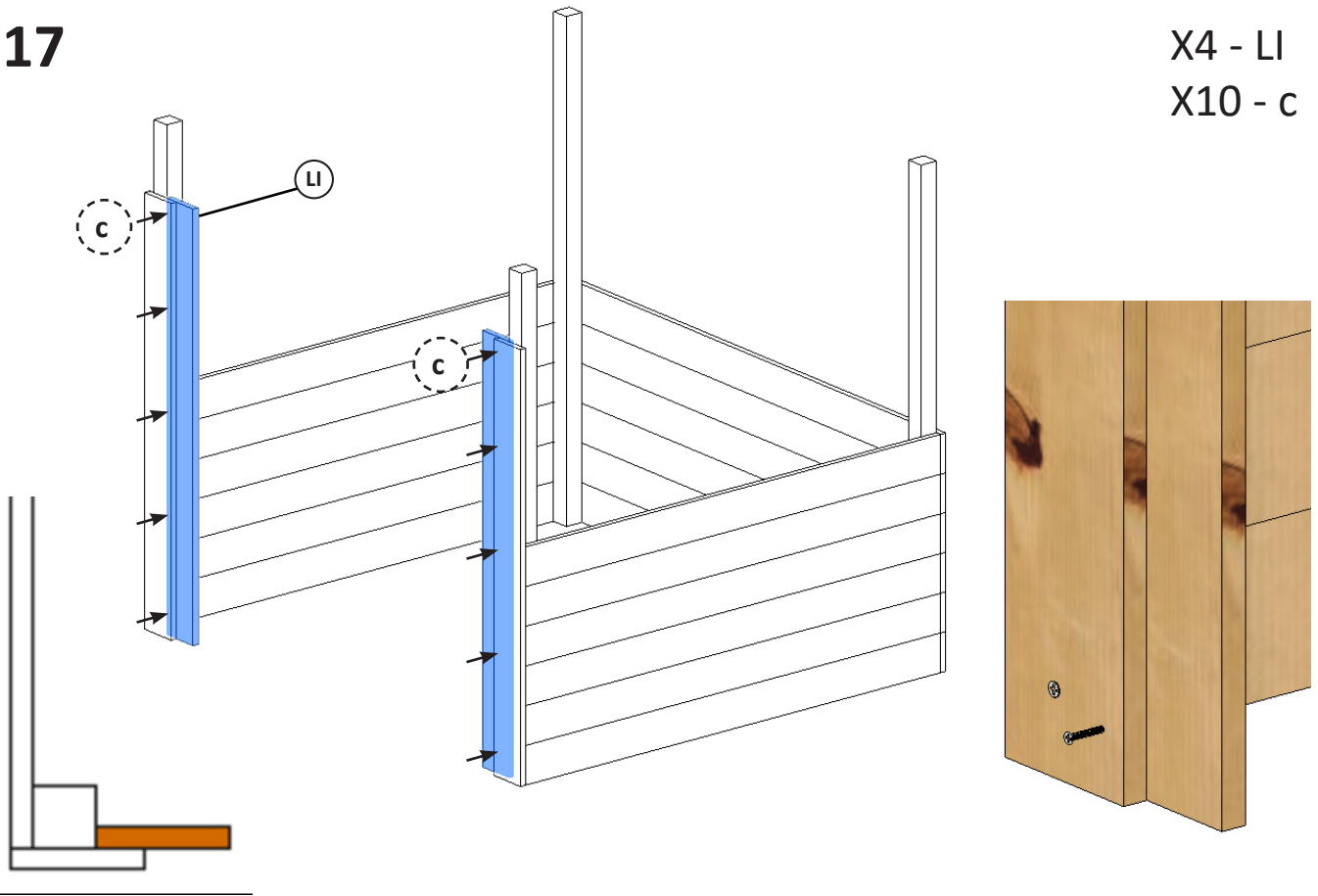

18

X12 - LP
X24 - c

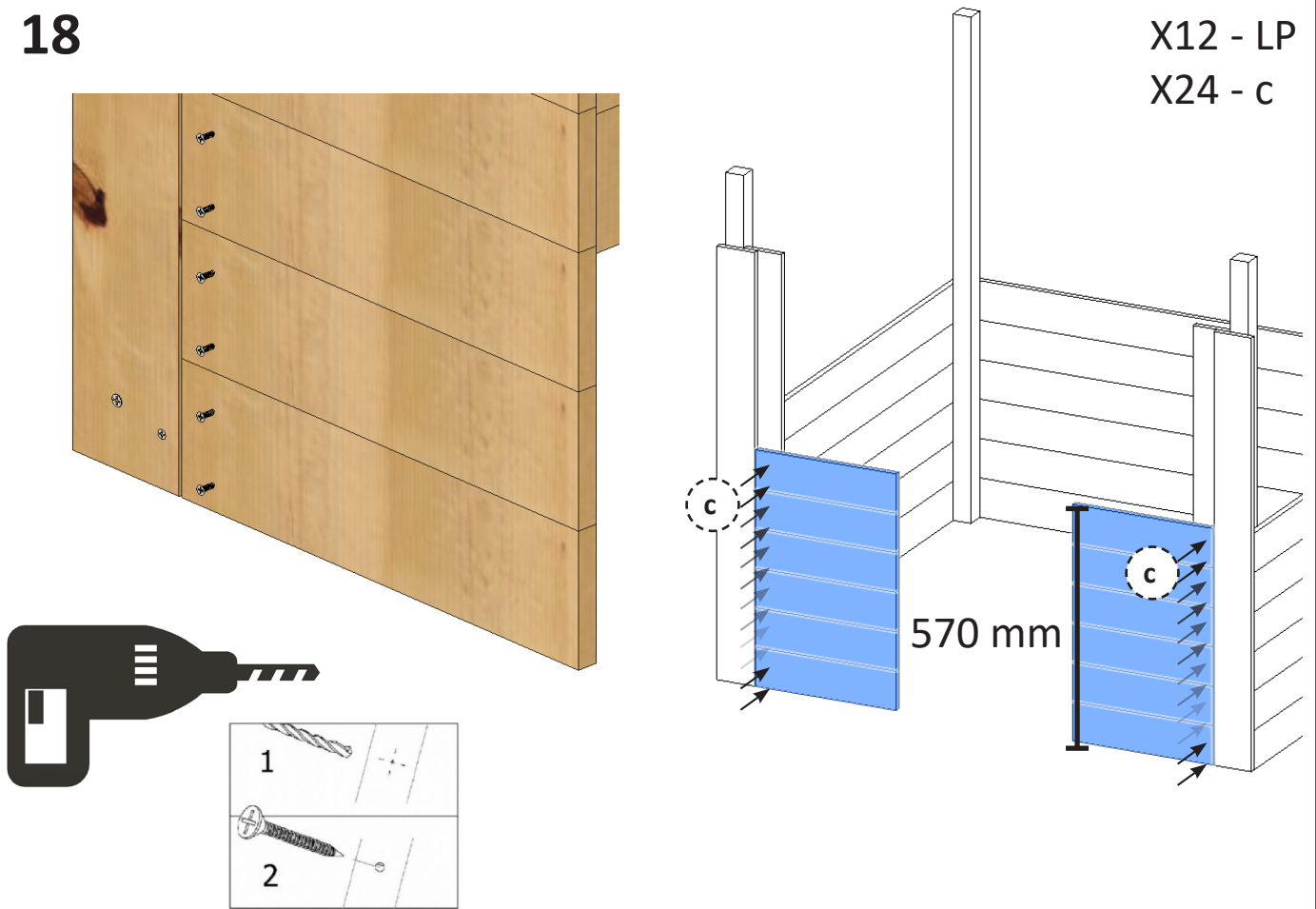

19

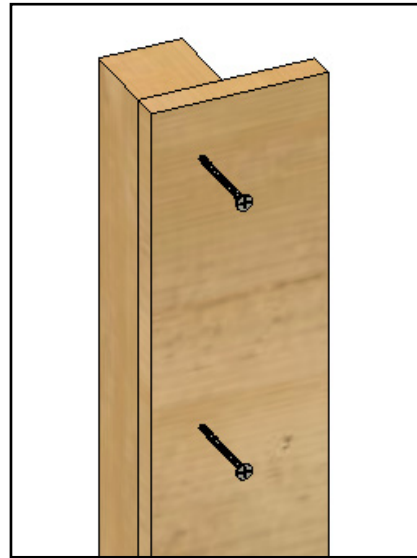
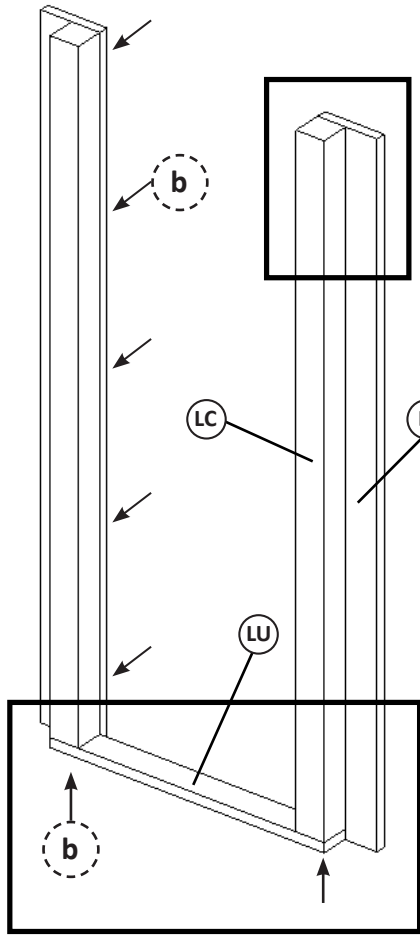

X2 - LC
X2 - LI
X1 - LU
X12 - b

20

X24 - c

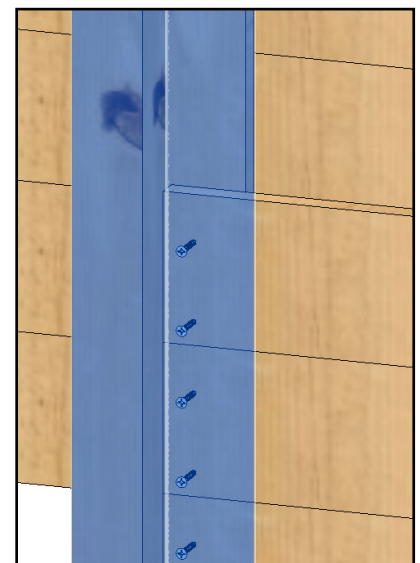
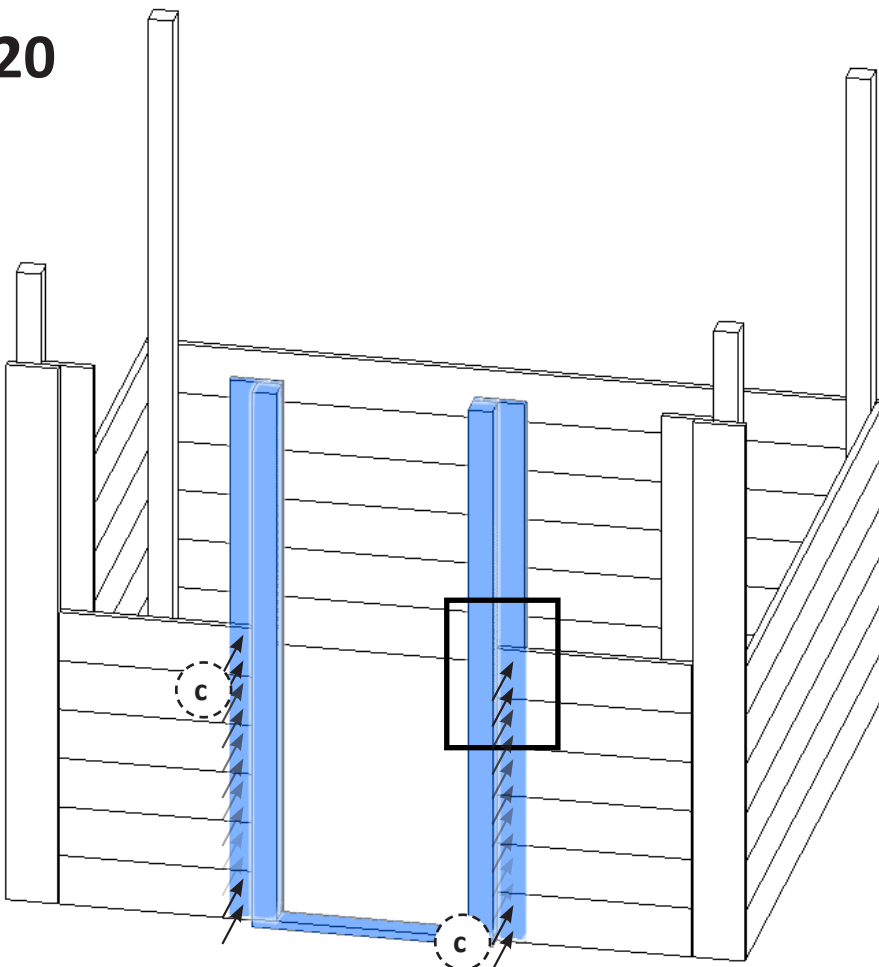

21

X2 - AA
X8 - c

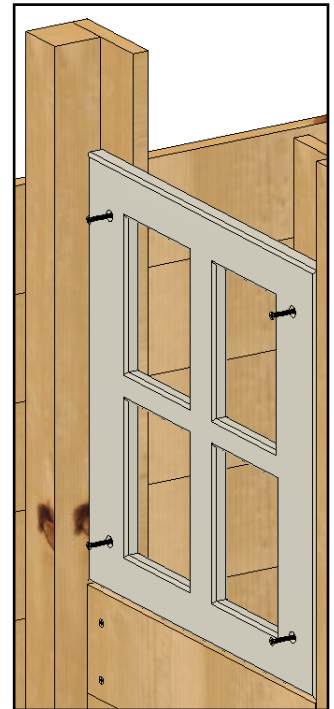
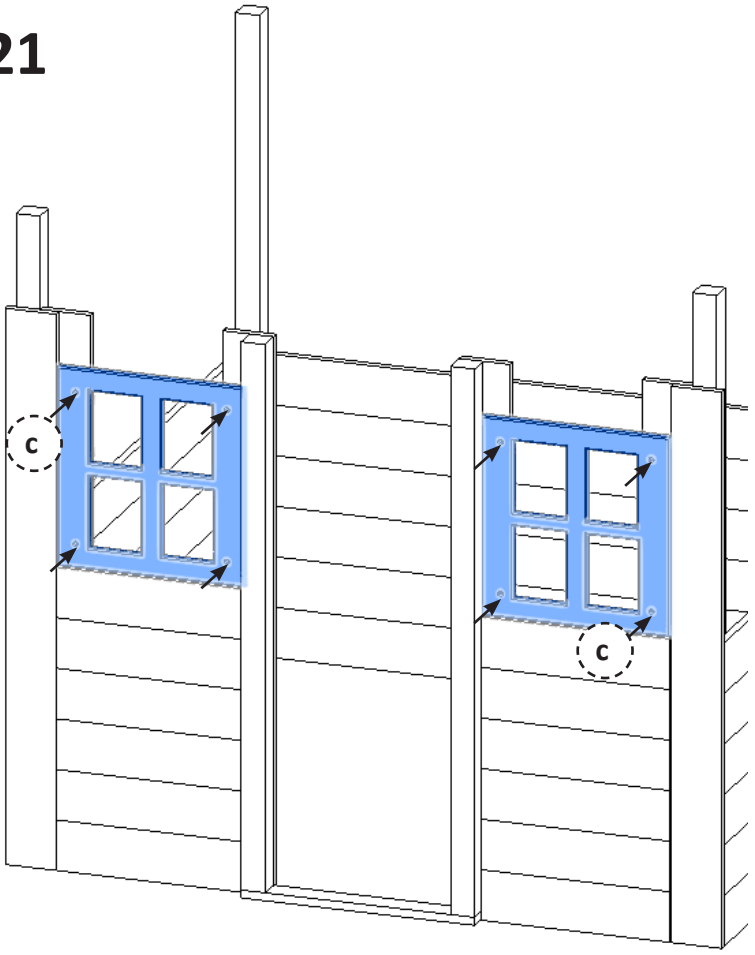

22

X2 - LP
X8 - c

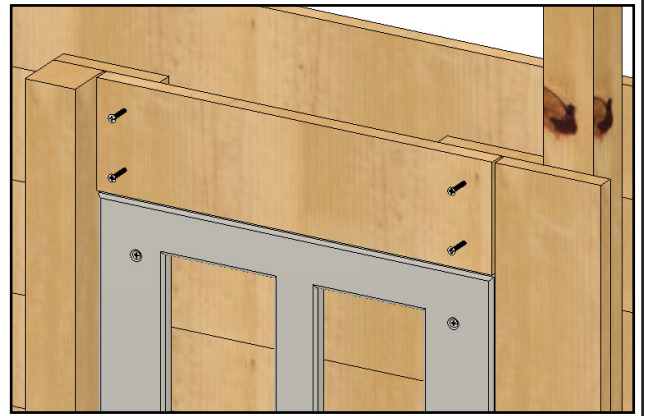
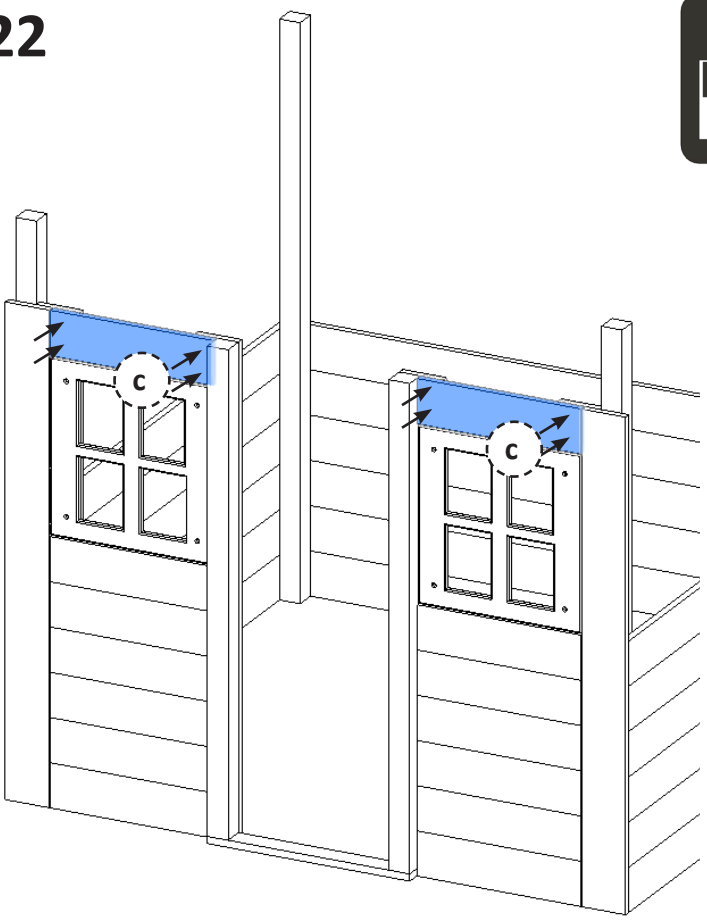
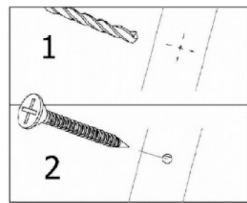
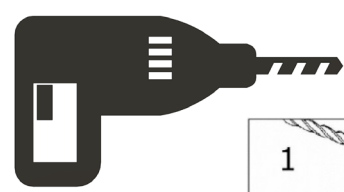

23

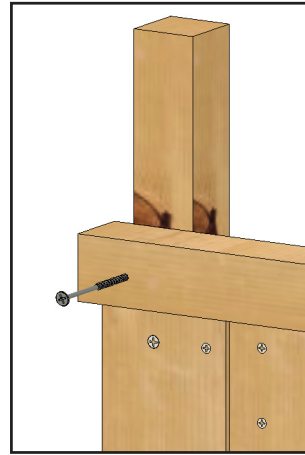
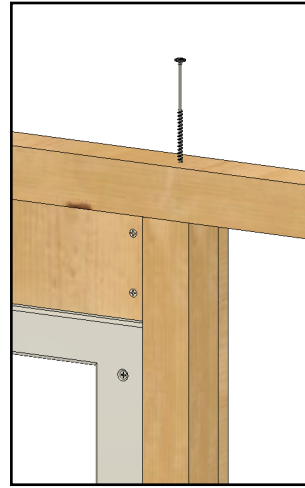
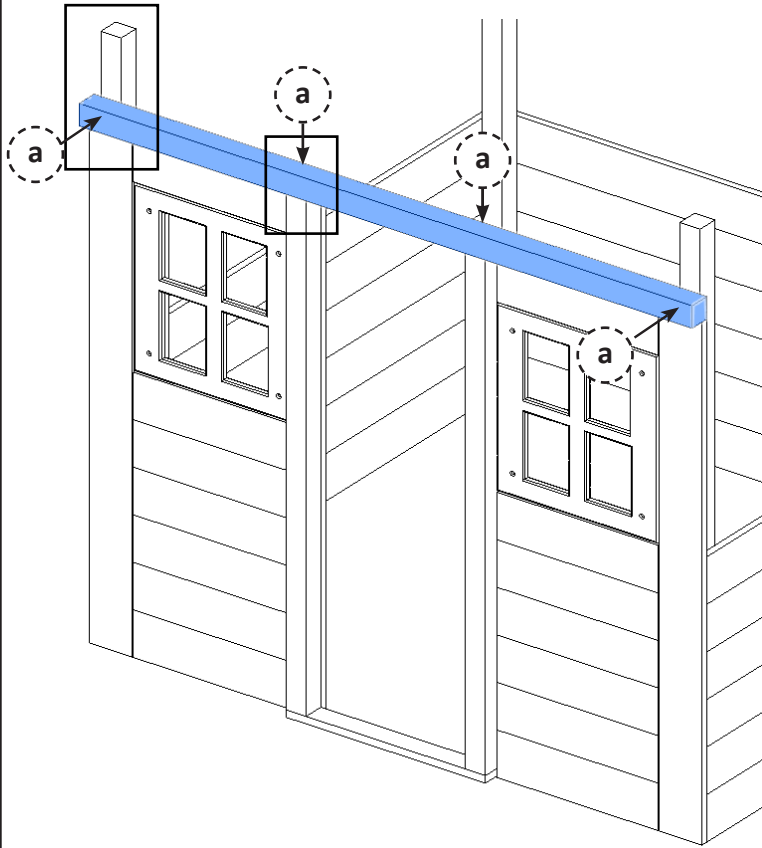

X1 - LA
X4 - a

24

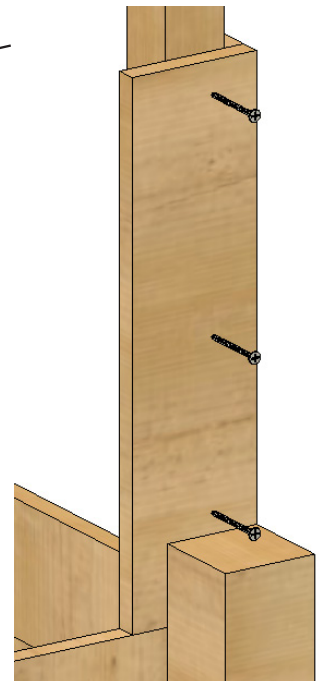
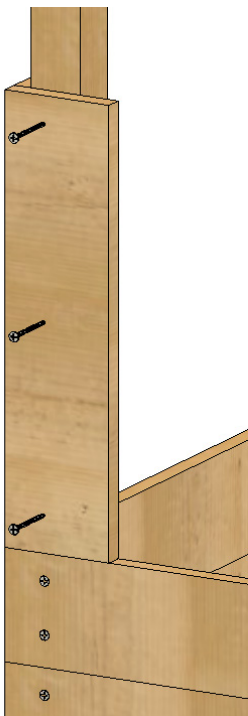
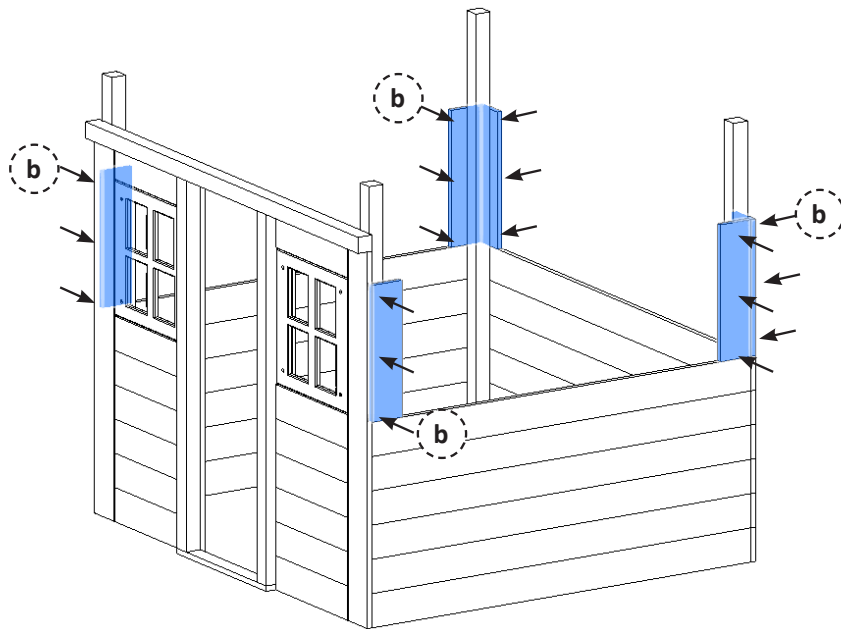

X6 - LN
X18 - b

25

X2 - LF
X4 - LG
X24 - b

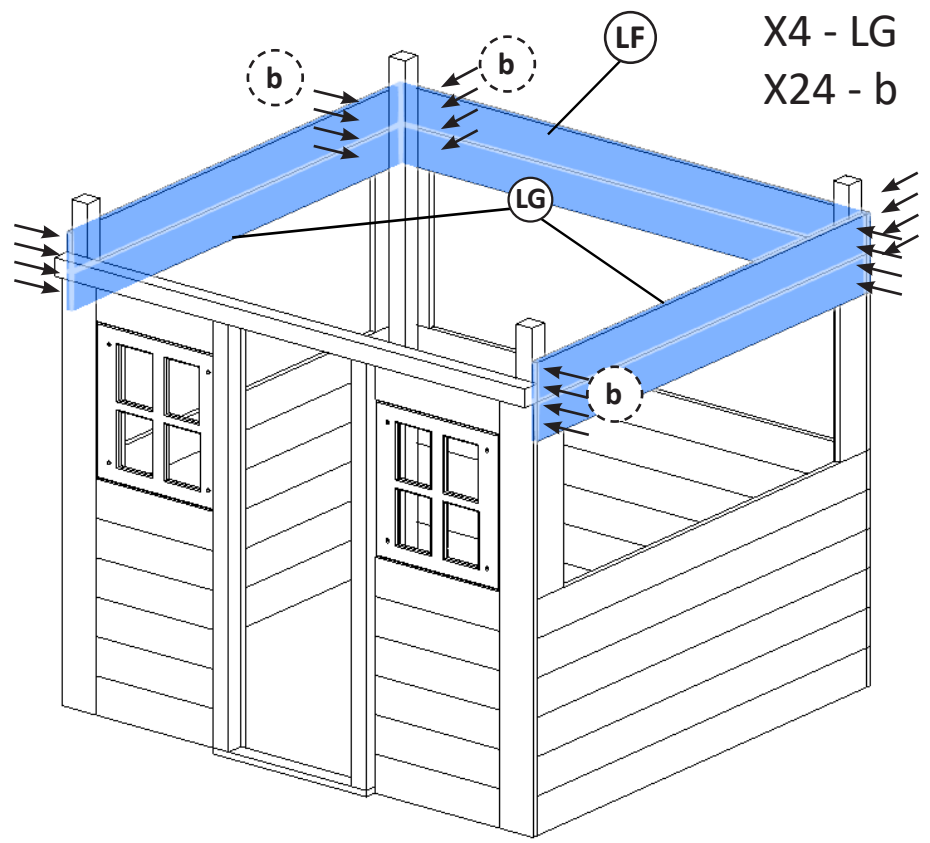
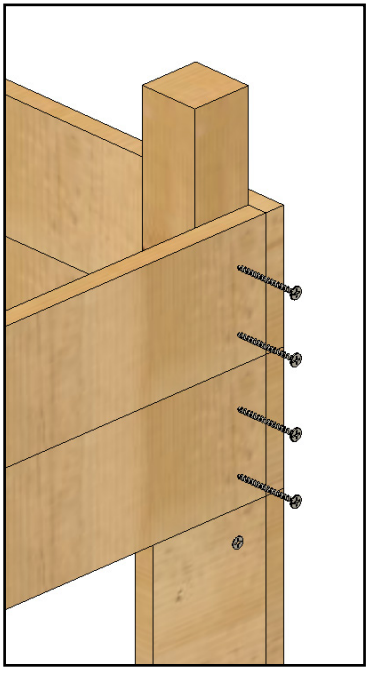

26

X12 - LM
X48 - c

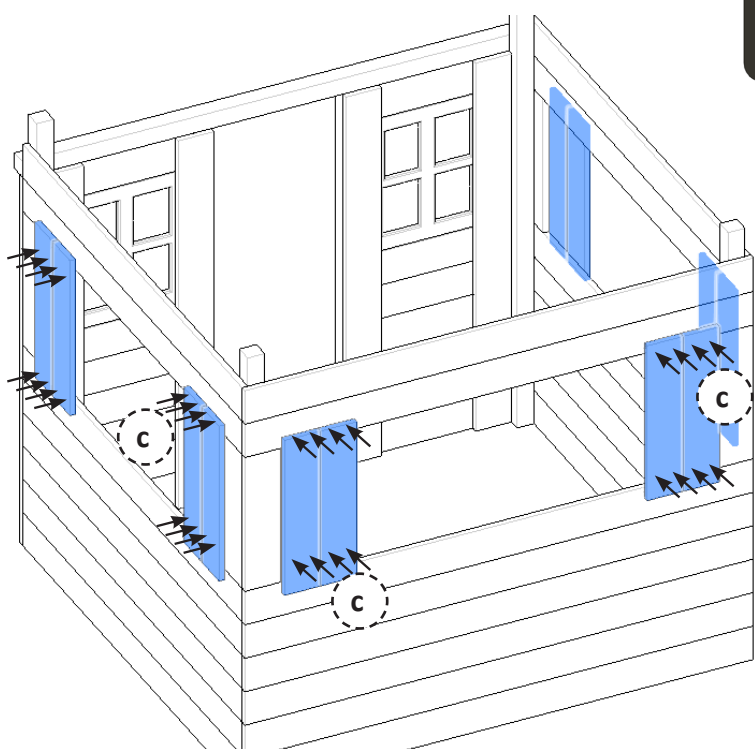
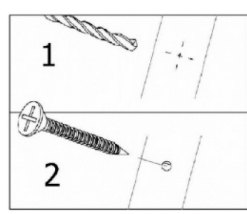
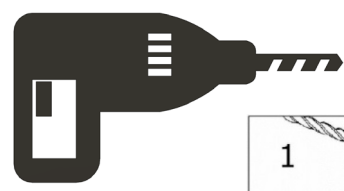

27

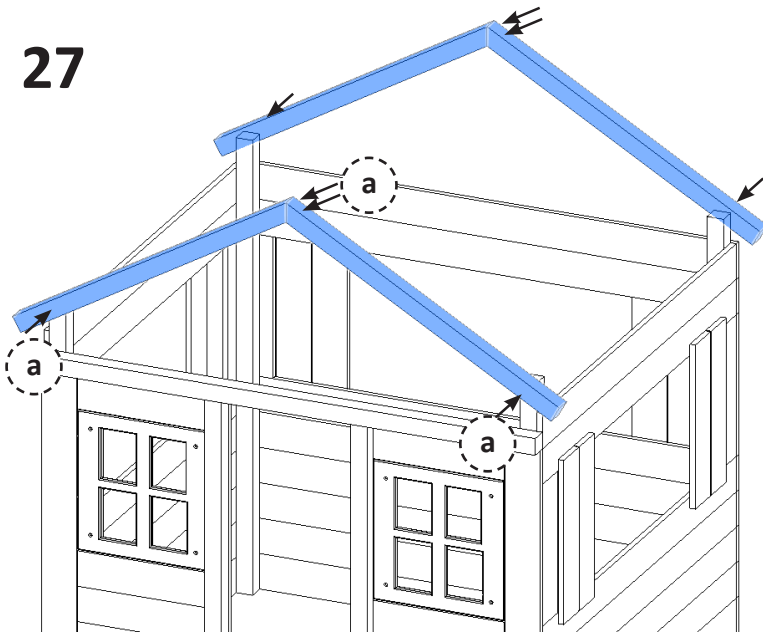

X4 - LD
X8 - a

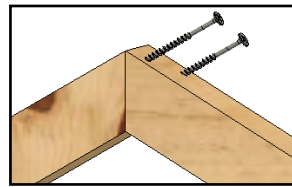
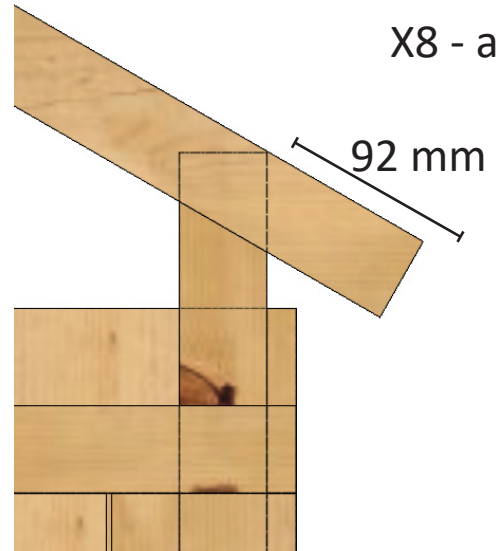

ESP En caso de que la madera de abajo impida colocar la viga de la manera mostrada,
ENG In case the wood below prevents placing the beam as shown, remove it and cut it to the necessary size
FRA Au cas où le bois en dessous empêcherait de placer la poutre comme indiqué, retirez-le et coupez-le à la taille nécessaire.
PT Caso a madeira abaixo impeça de colocar a viga como mostrado, remova-a e corte-a no tamanho necessário
CAT En cas que la fusta de sota impedeixi col·locar la biga de la manera mostrada, retireu-la i tal·leu-la a la mida necessària

28

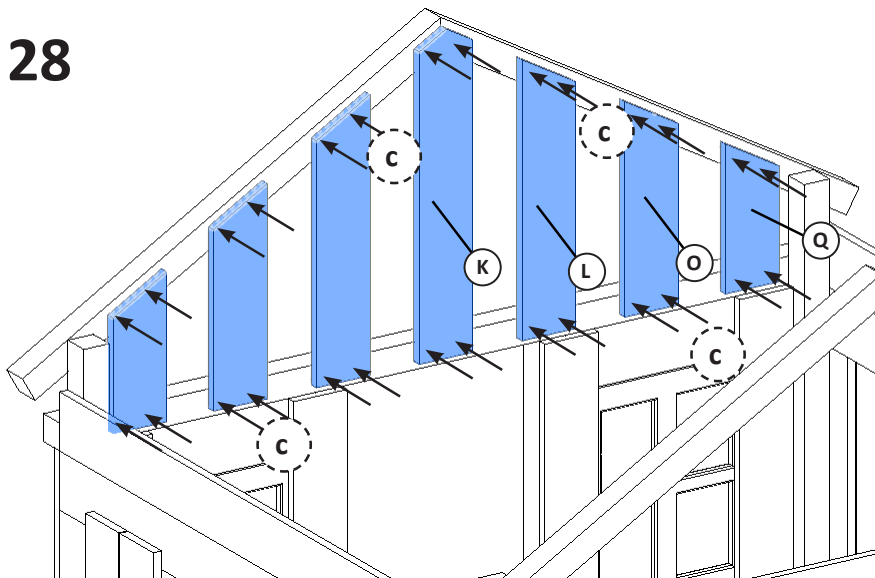

X1 - LK
X2 - LL
X2 - LO
X2 - LQ
X28 - c

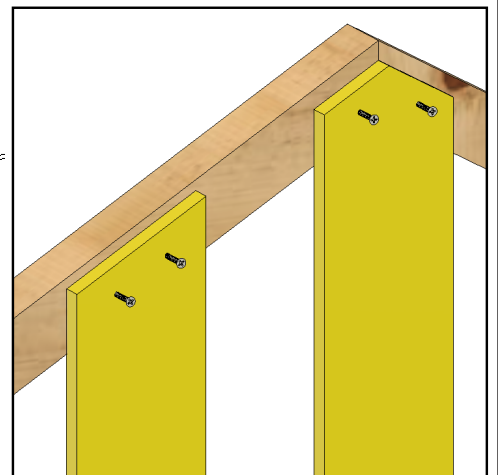

29

- X1 - LK
- X2 - LL
- X2 - LO
- X2 - LQ
- X28 - c

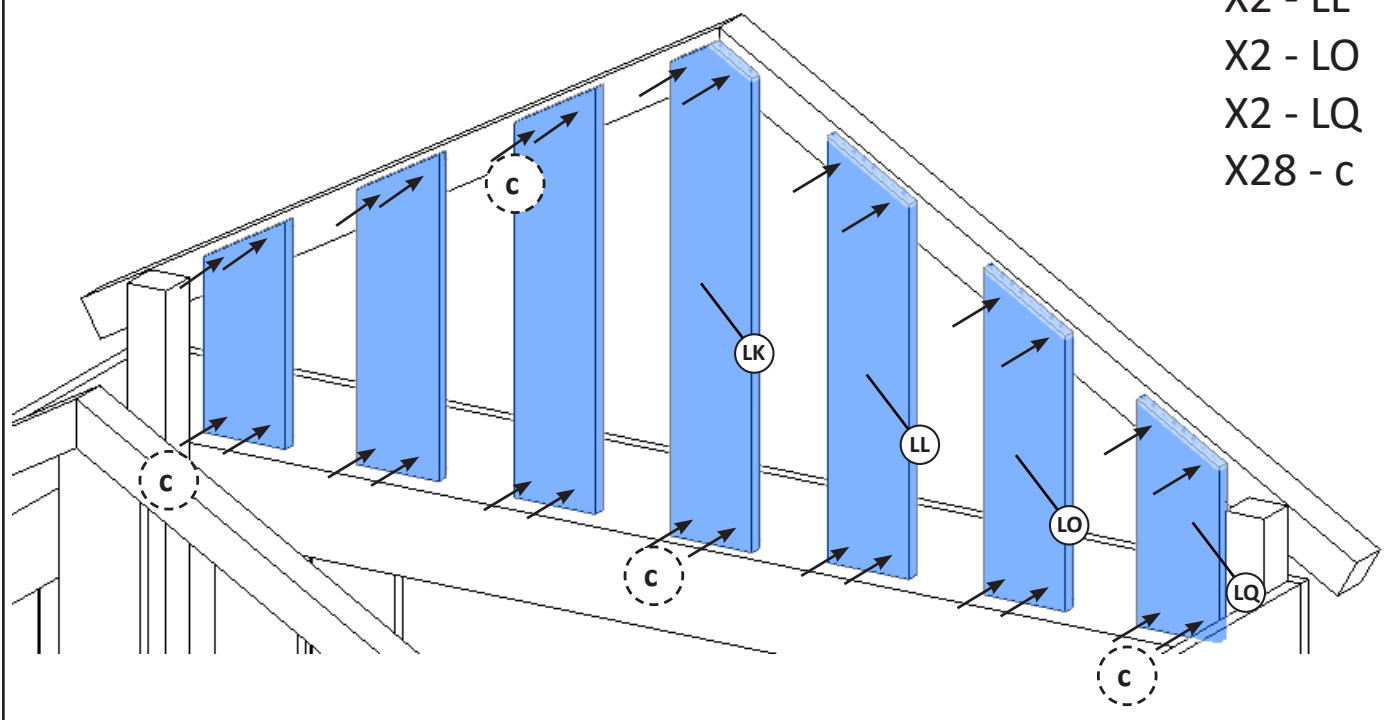

30

- X18 - LE
- X72 - e

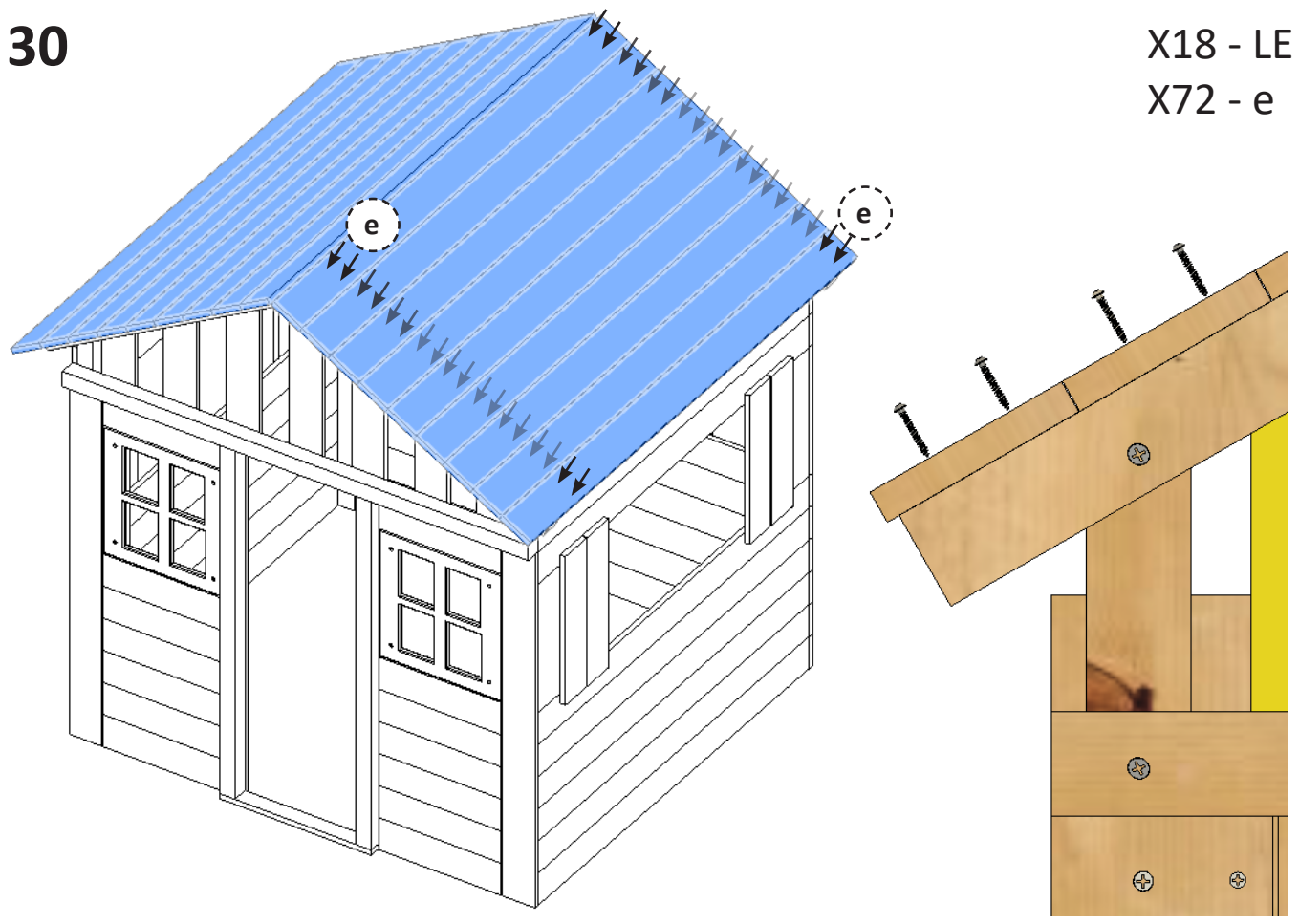

31

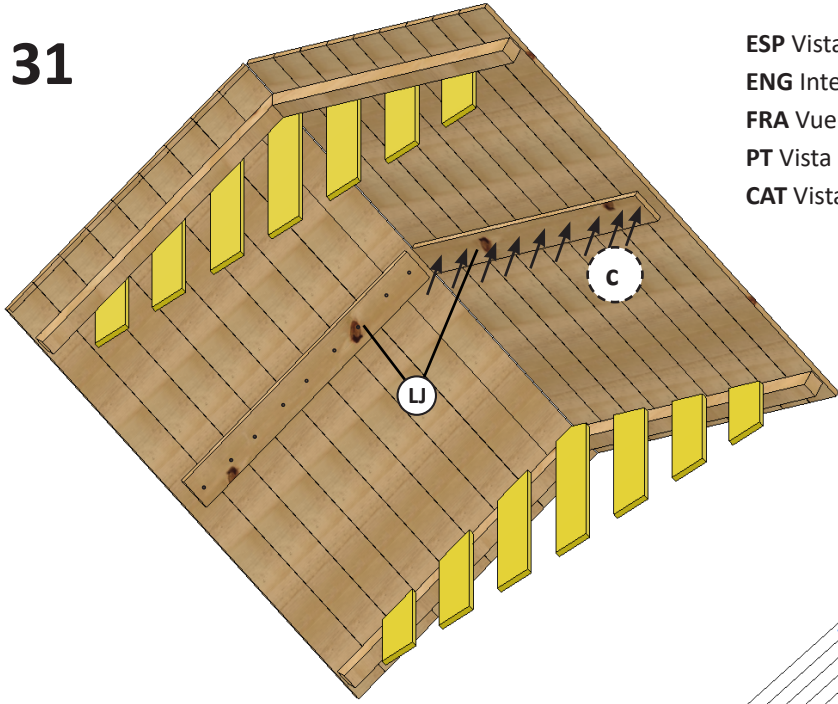

ESP Vista interior.
ENG Interior view.
FRA Vue intérieure.
PT Vista interior.
CAT Vista interior.

X2 - LJ
X18 - c

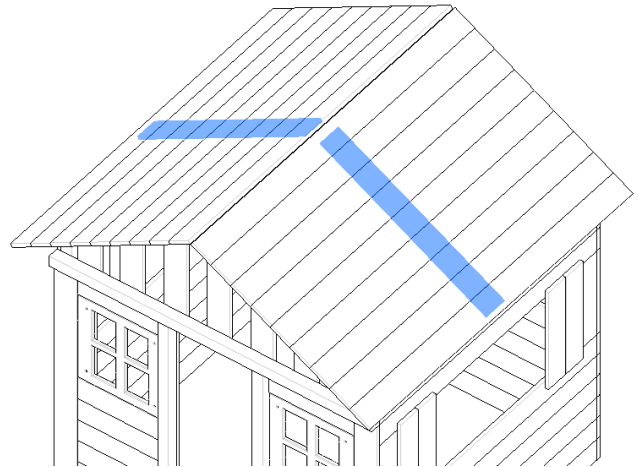

32

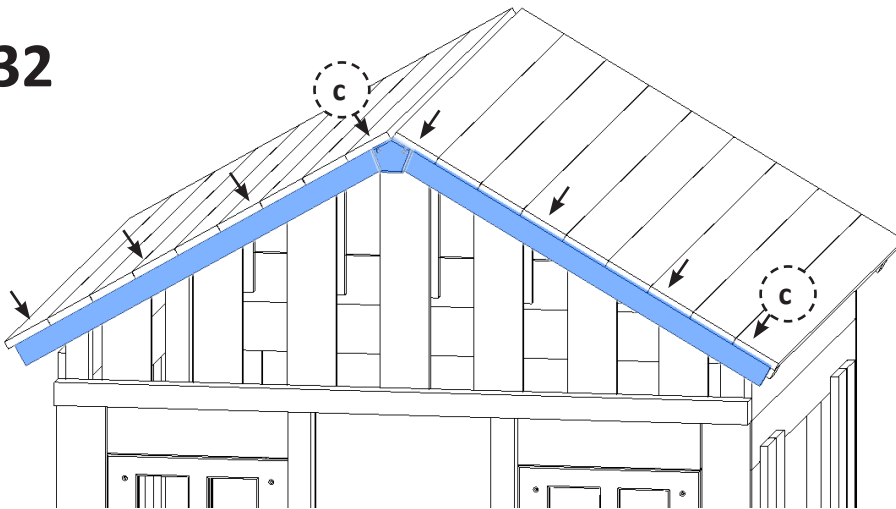

X2 - LT
X1 - BB
X10 - c

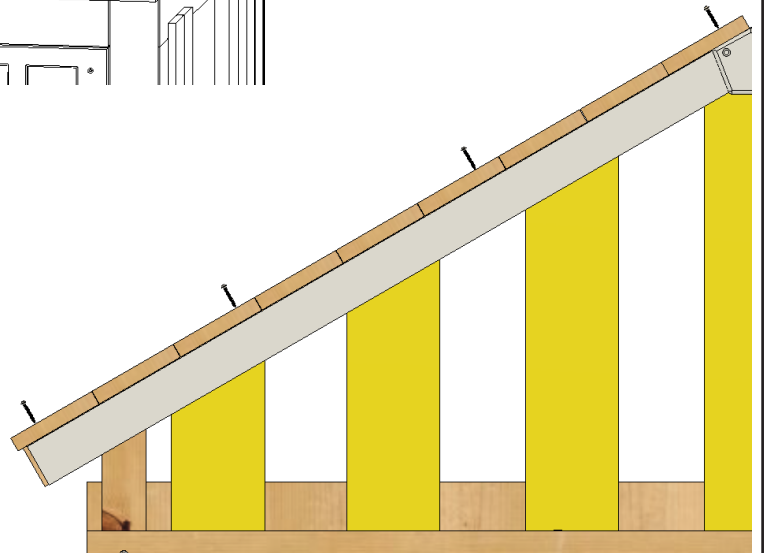
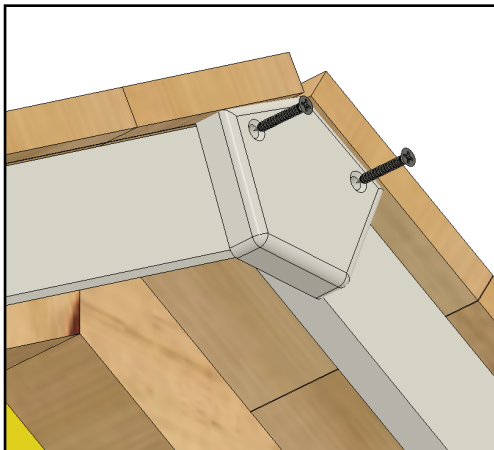

33

X2 - LX
X8 - c

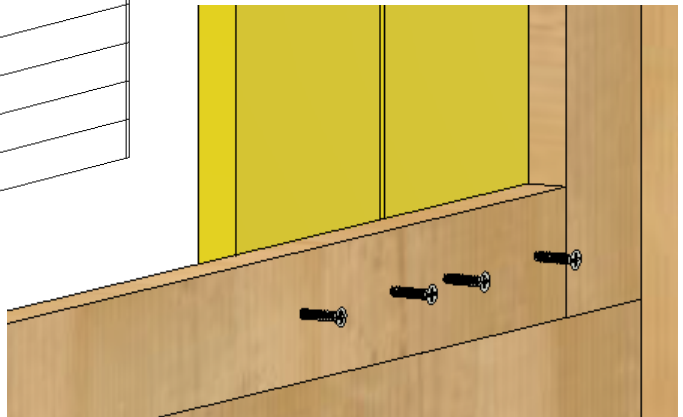
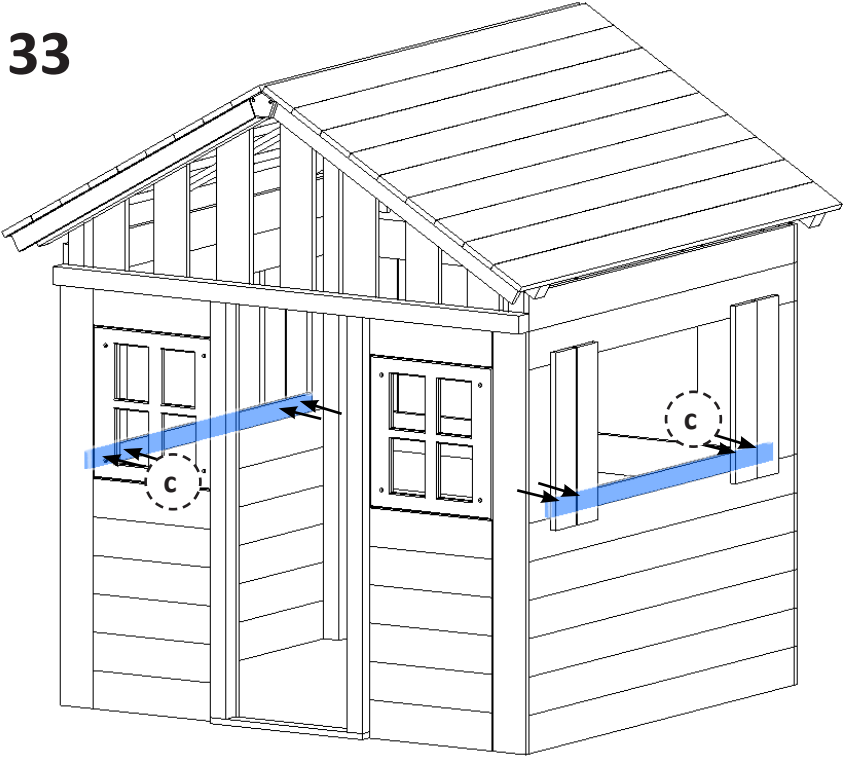

34

X1 - LW
X4 - c

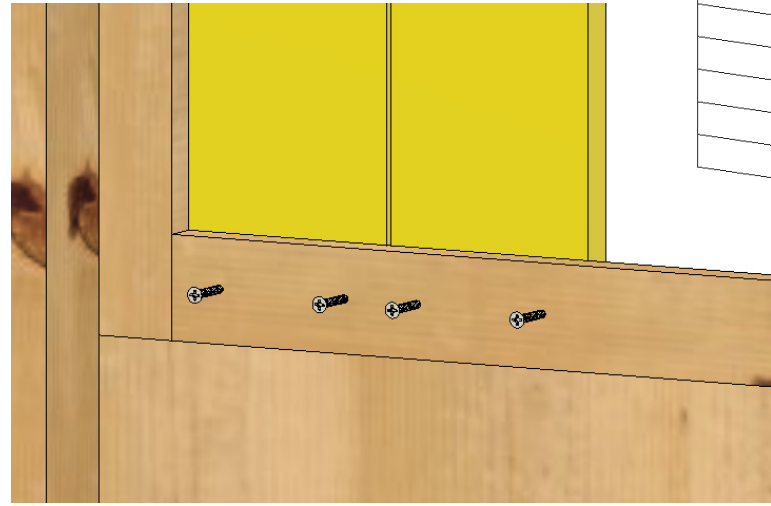
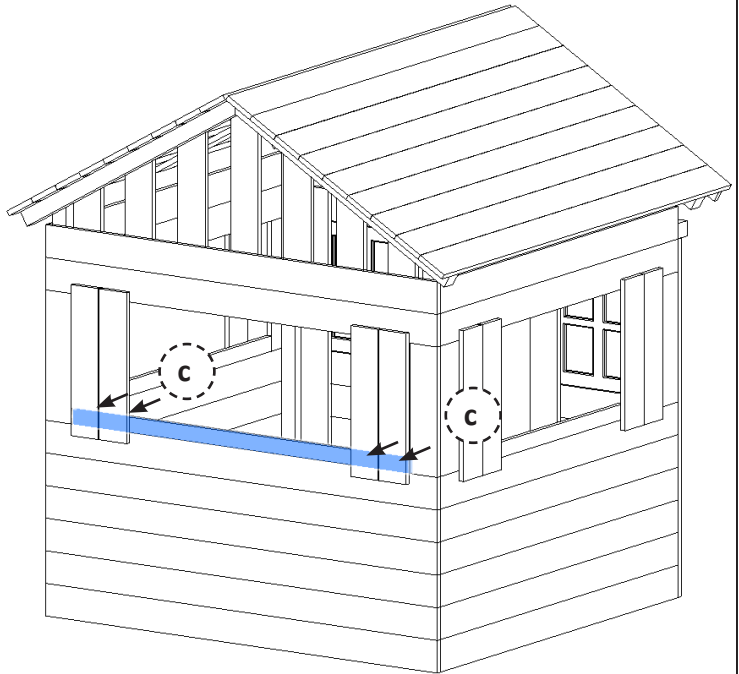

ESP Vista interior.
ENG Interior view.
FRA Vue intérieure.
PT Vista interior.

35

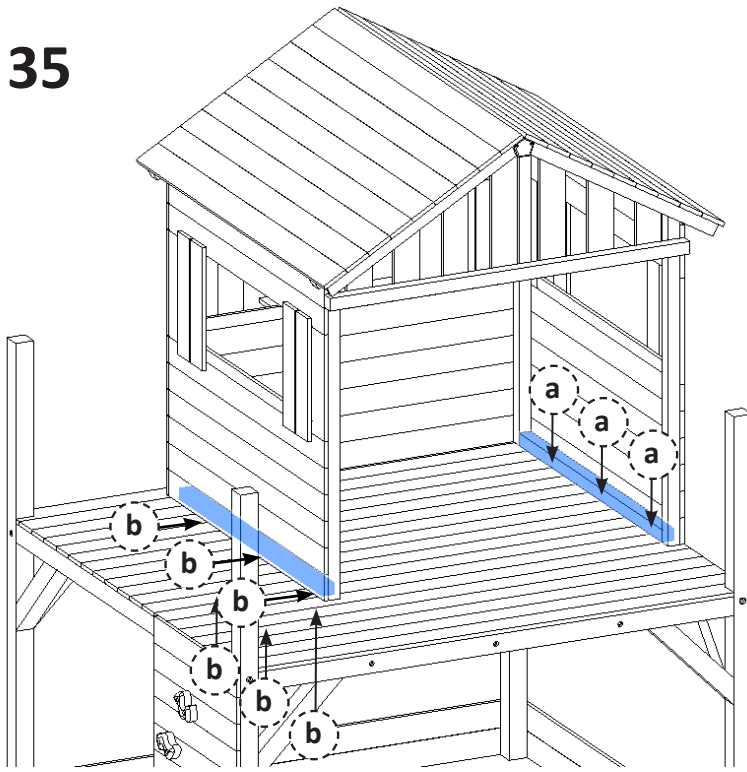

X2 - TY
X3 - a
X9 - b

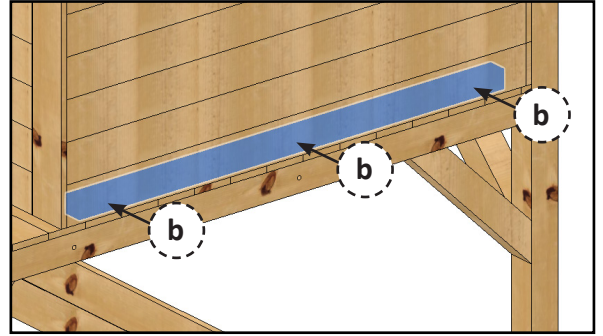

ESP Vista sin barandilla ni pared frontal de la casita.
ENG View without railing or front wall of the cottage.
FRA Vue sans garde-corps ni mur avant de la maison.
PT Vista sem corrimão ou parede frontal da cabana.
CAT Vista sense la barana ni la paret frontal de la caseta.

36

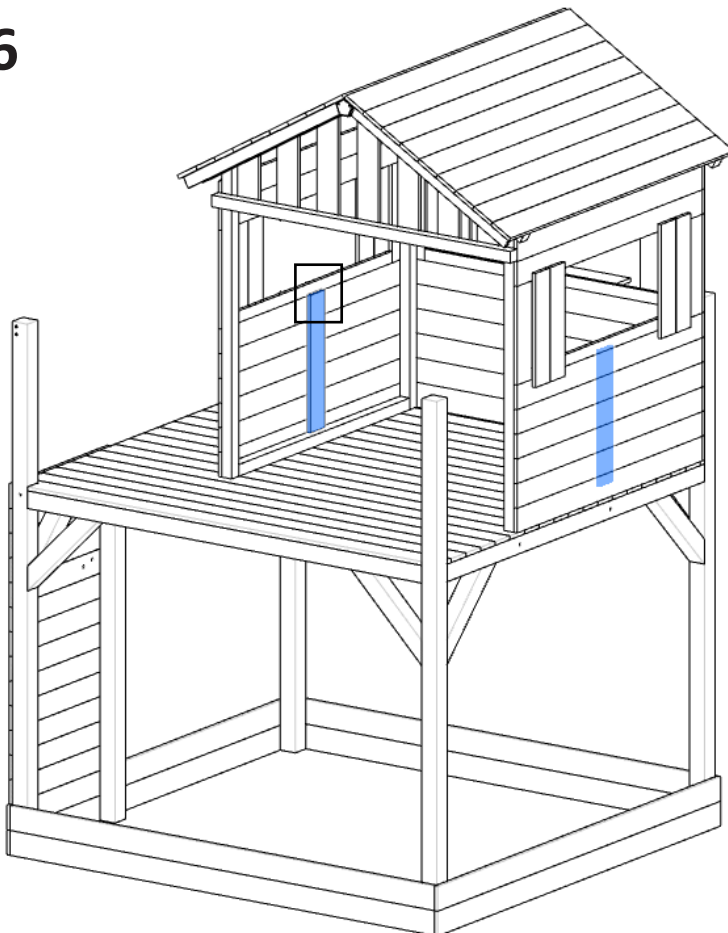

X2 - LV
X24 - c



37

X1 - LV
X1 - TX
X6 - b
X12 - c

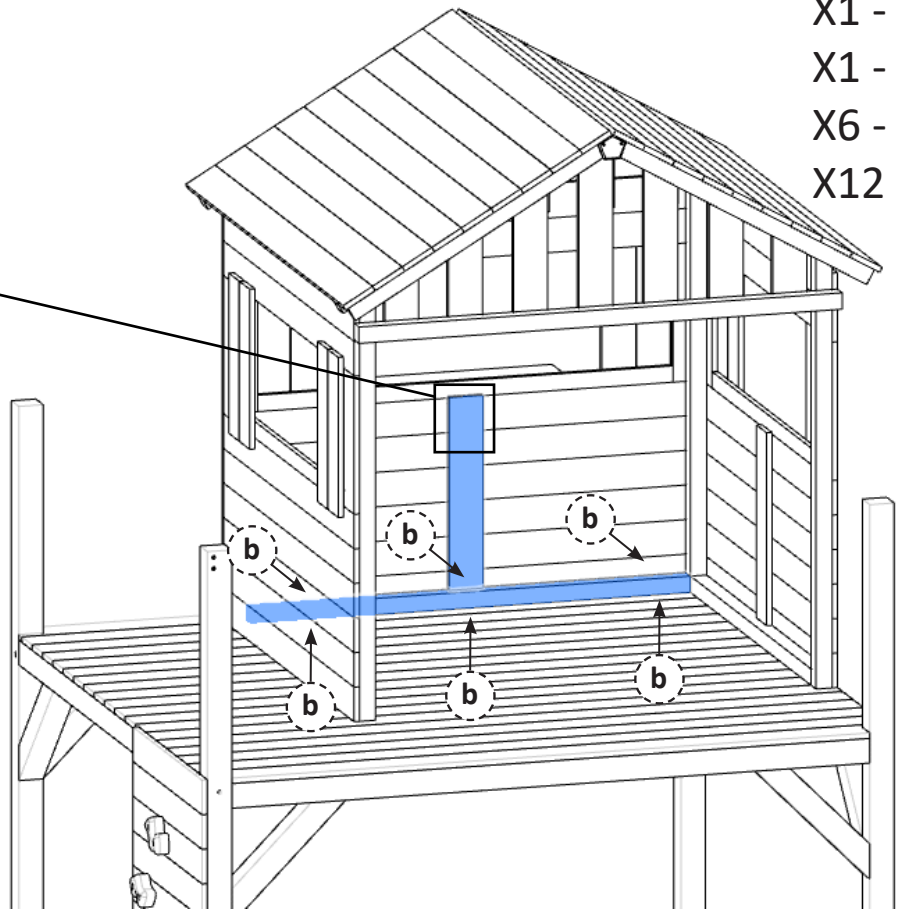
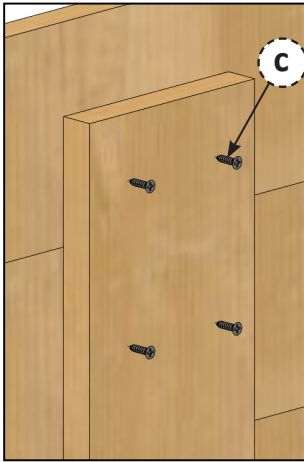

38

X3 - c

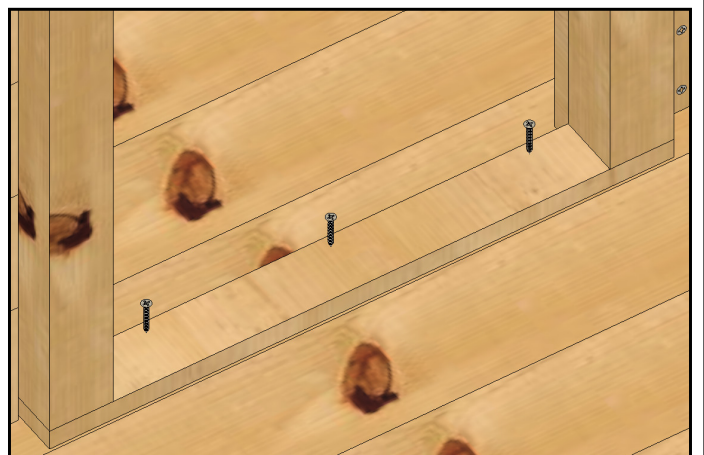
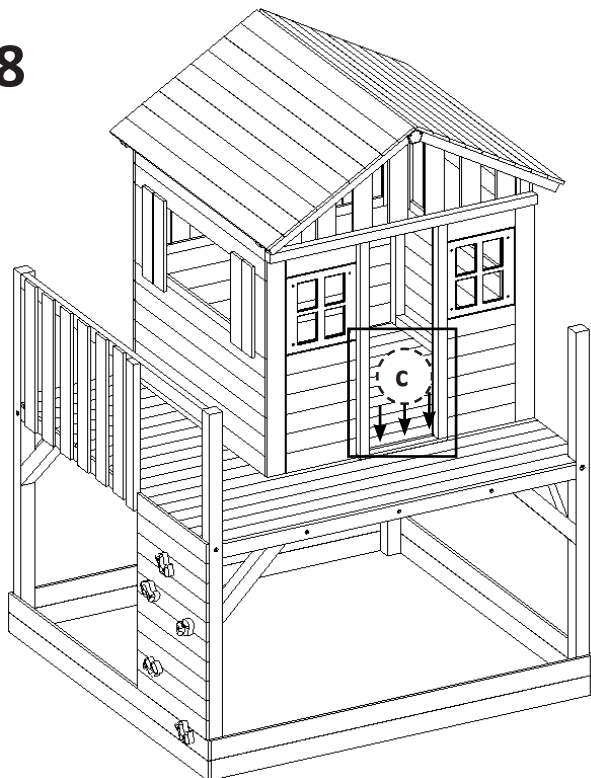

ESP Vista sin barandilla.
ENG View without railing.
FRA Vue sans garde-corps.
PT Vista sem corrimão.
CAT Vista sense la barana.

39

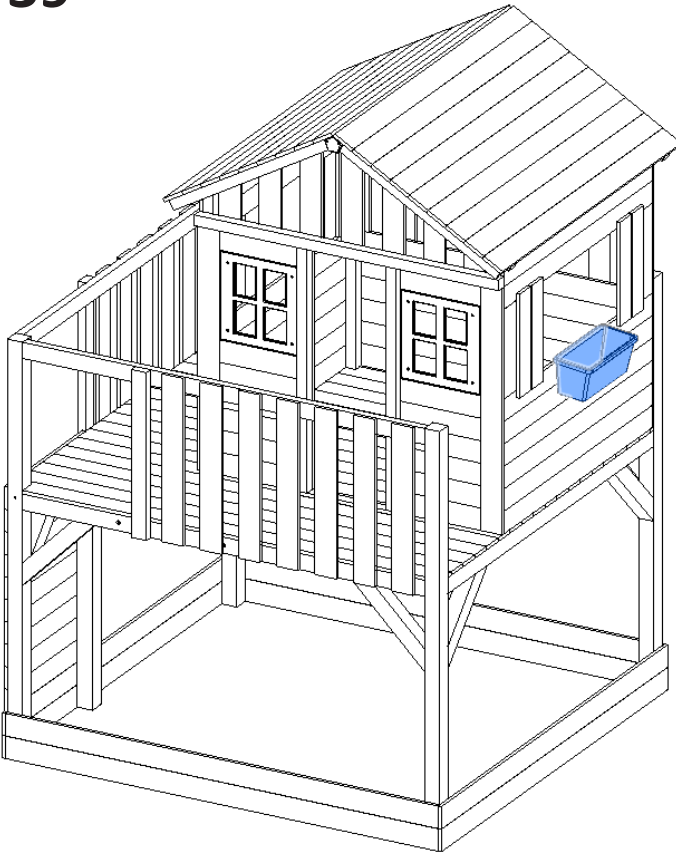

X1 - EE
X2 - l
X2 - m
X2 - q'

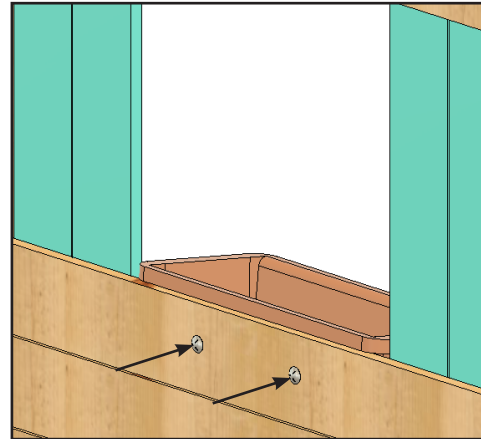

ESP Asegurese de hacer coincidir los agujeros de la maceda y la madera. Marquenlos antes de taladrar.
ENG Make sure the holes in the planter and the wood are aligned. Mark the holes before drilling
FRA Assurez-vous de faire correspondre les trous de la jardinière et du bois. Marquez-les avant de percer
PT Certifique-se de combinar os orifícios da plantadeira e da madeira. Marque-os antes de furar.
CAT Asseguri's que els forats del test i la fusta estiguin aliniat. Marqui abans de foradar.

40

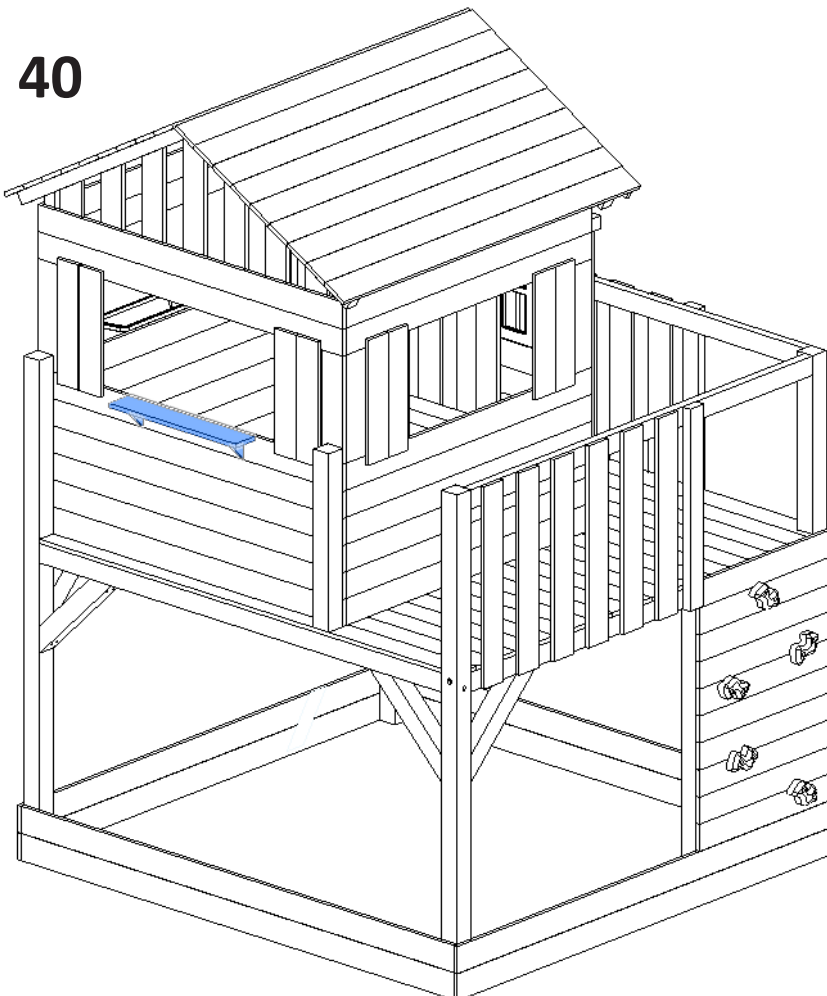

X1 - FF
X4 - c

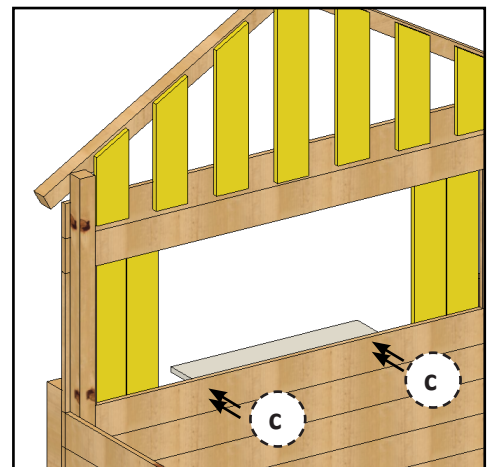

41

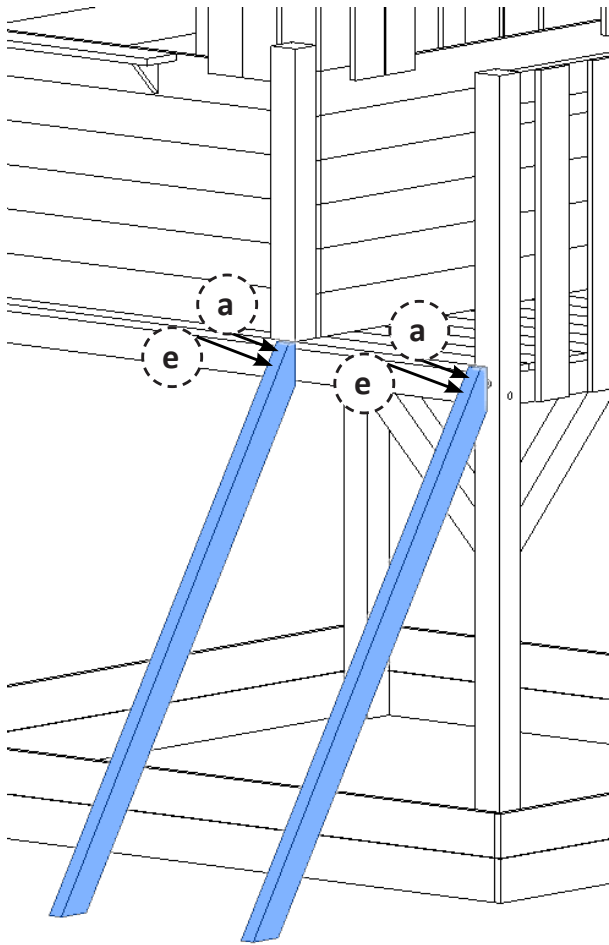

X2 - TI
 X2 - a
 X2 - e

ESP Vídeo de montaje de la escalera.
 ENG Ladder assembly video.
 FRA Vidéo de montage d'échelle.
 PT Vídeo de montagem de escada.
 CAT Vídeo de muntatge de l'escala.

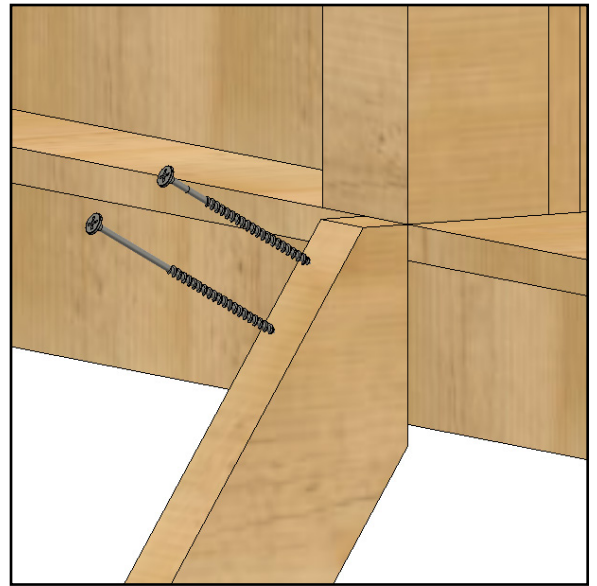

42

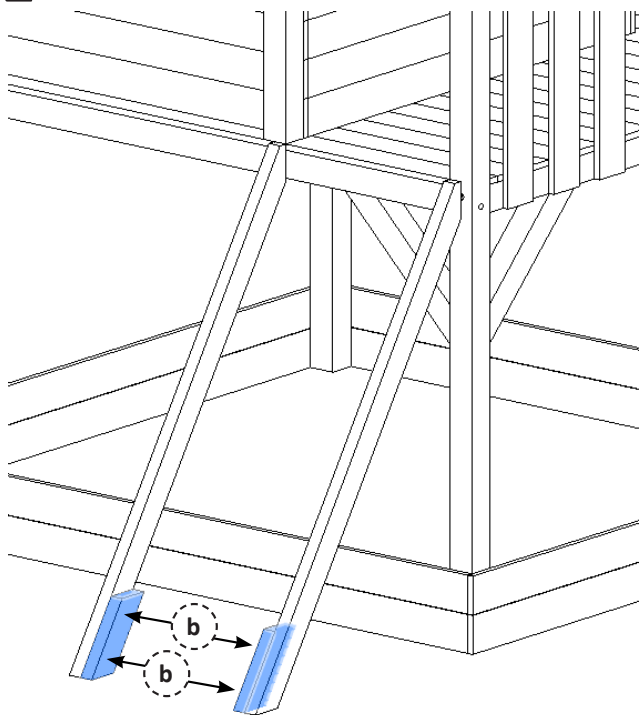

Parque L
 X2 - TP
 X4 - b
 Parque XL
 X2 - TO
 X4 - b

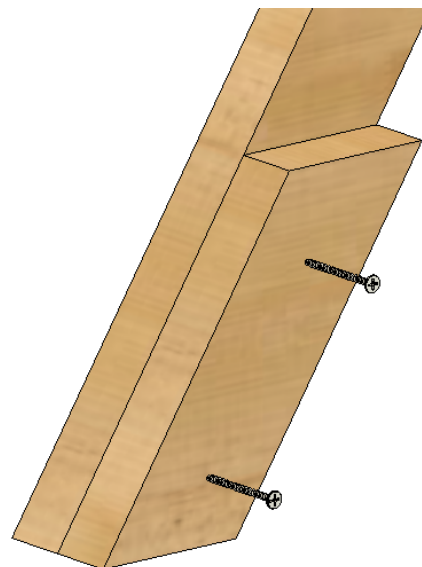

43

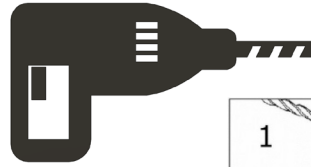

X1 - TQ
X4 - b

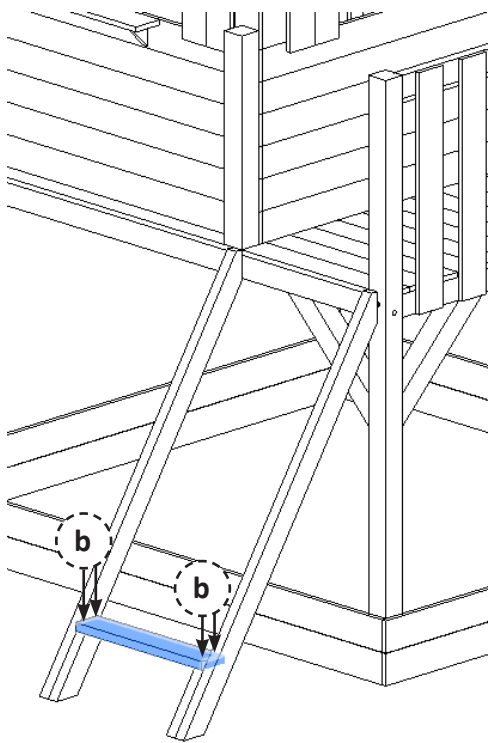
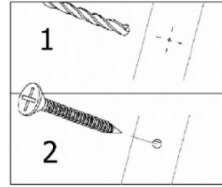

44

PARQUE LOLLIPOP L

PARQUE LOLLIPOP XL

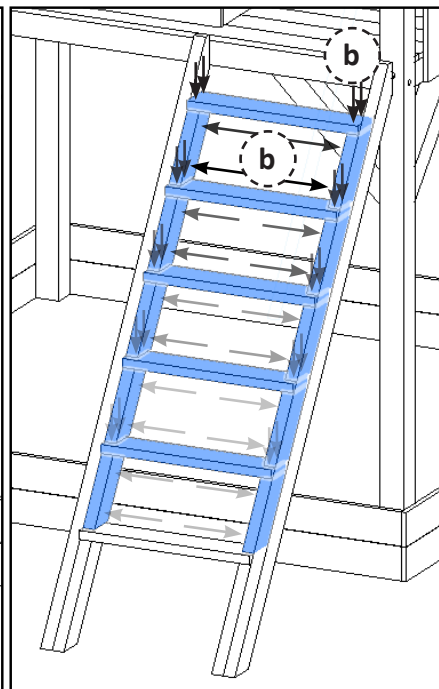
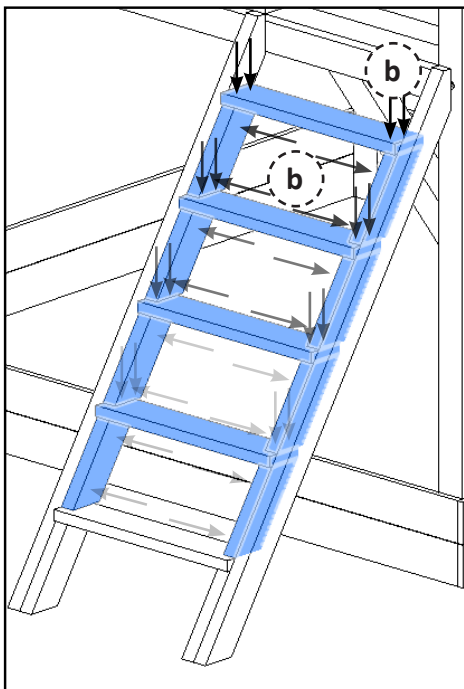

Parque L
X8 - TP
X4 - TQ
X32 - b
Parque XL
X10 - TP
X5 - TQ
X40 - b

ESP Asegurese que las piezas estan firmemente apoyadas. Presione hacia abajo durante la instalcion de escalones y los soportes.

ENG Make sure the pieces are firmly supported. Press down during the installation of scales and supports.

FRA Assurez-vous que les pièces sont fermement soutenues. Appuyez pendant l'installation des échelles et des supports.

PT Certifique-se de que as peças estão firmemente apoiadas. Pressione para baixo durante a instalação de passos e suportes.

CAT Asseguris que les peces estan fermament recolzades. Presioni cap avall durant la instal·lació dels esglaons i dels suports.

45

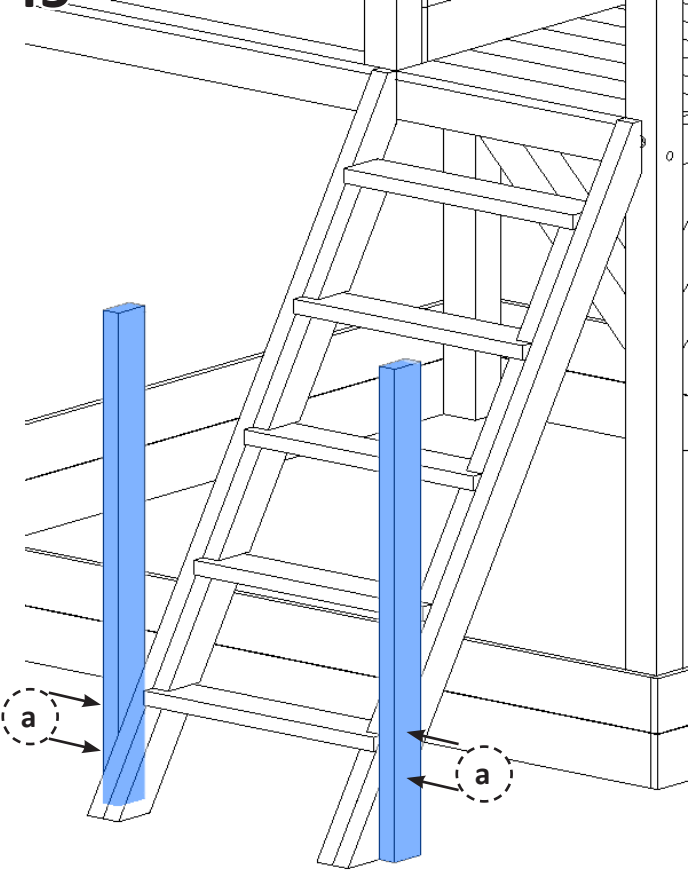

X2 - TK
X4 - a



46

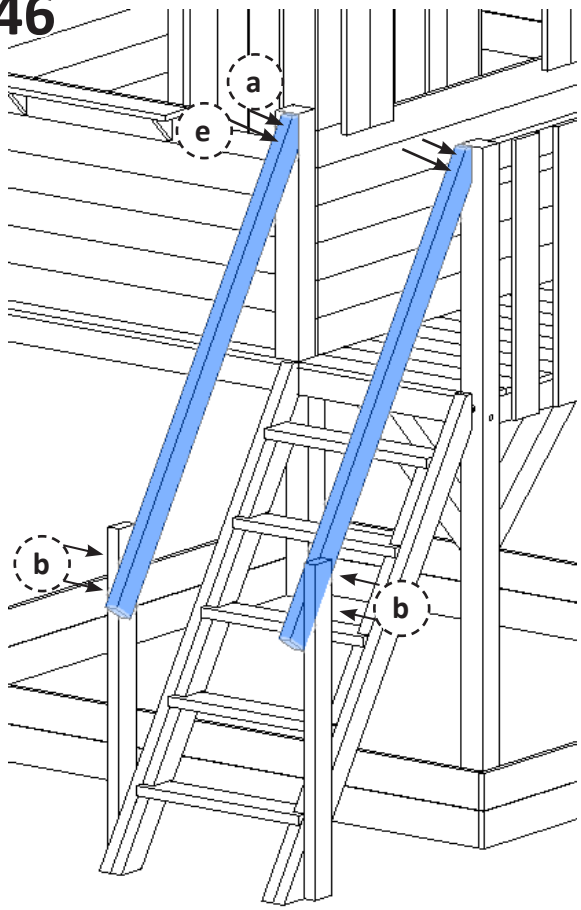

X2 - TH
X2 - a
X4 - b
X2 - e

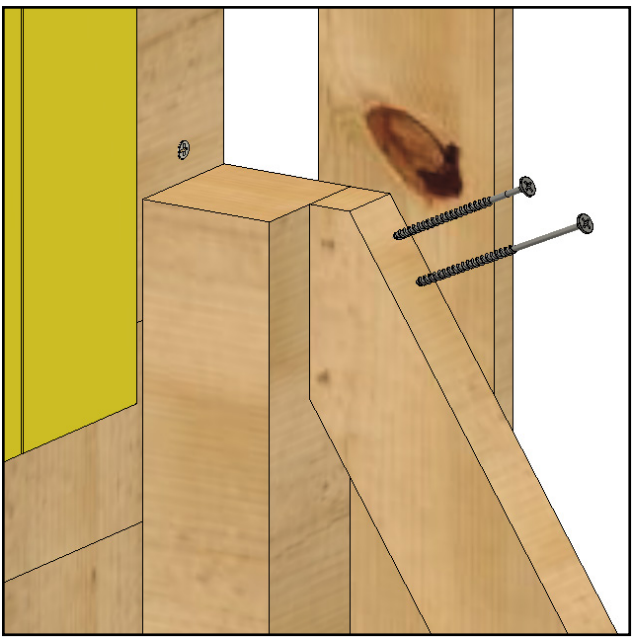

47

ESP Paso solo necesario para la instalación del columpio.

ENG Step only necessary for the installation of the swing.

FRA Étape seulement nécessaire pour l'installation de la balançoire.

PT Passo apenas necessário para a instalação do balanço.

CAT Pas només necessari per la instal·lació del gronxador.

X1 - GA

X1 - GB

X4 - b

X2 - e

X2 - f

X2 - r

X2 - o

X2 - q

X2 - DD

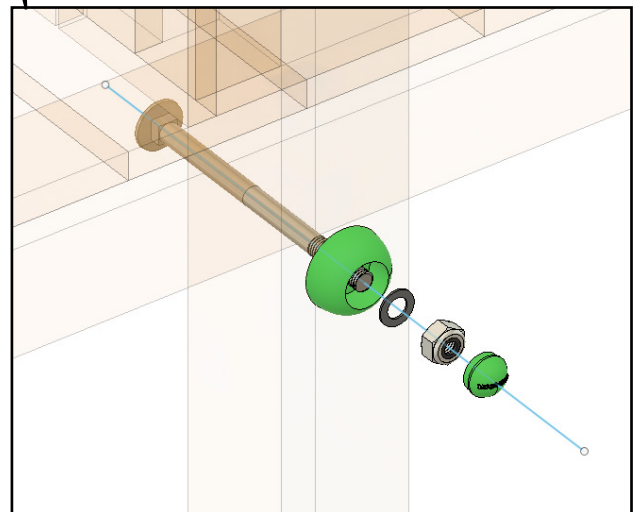
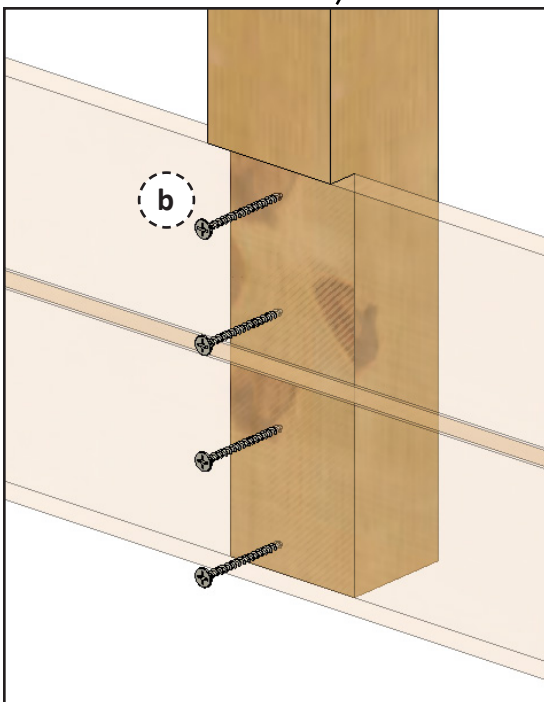
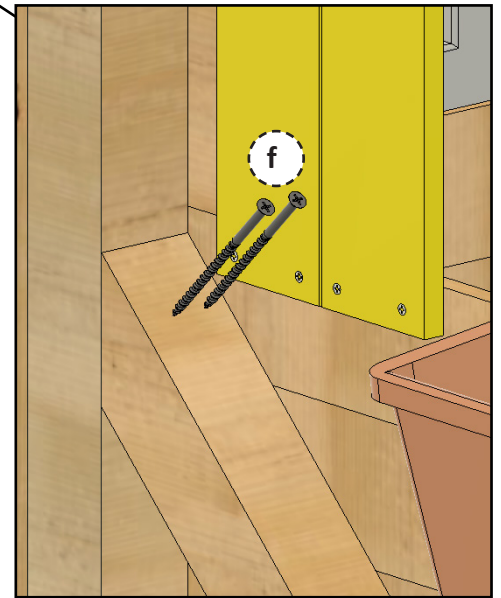
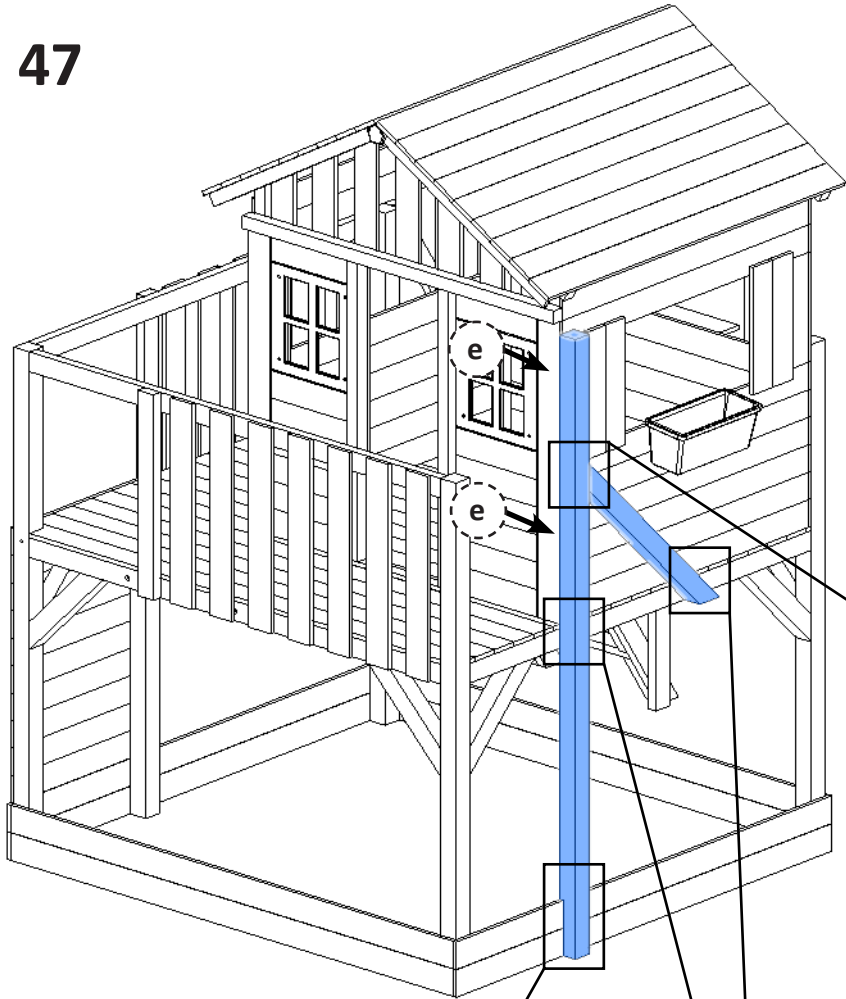

ESP Vista interior.
ENG Interior view.
FRA Vue intérieure.
PT Vista interior.
CAT Vista interior.

48

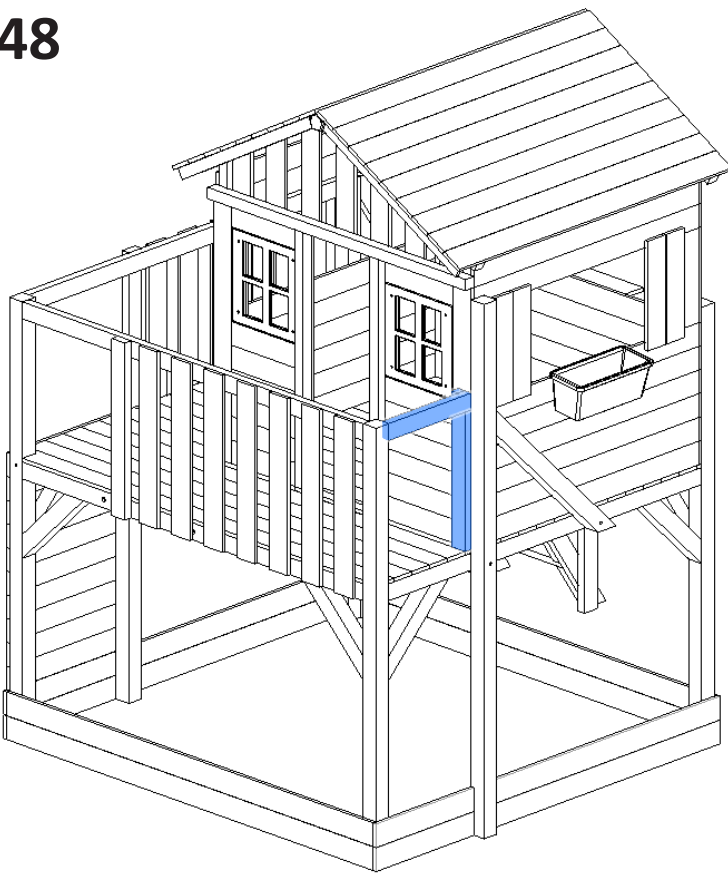

X1 - TM
 X1 - TN
 X3 - a
 X2 - e

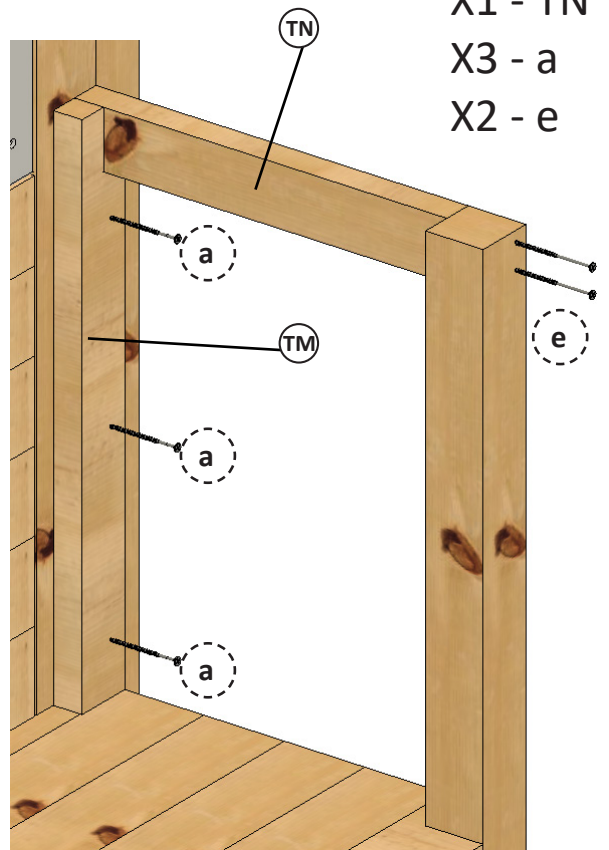

49

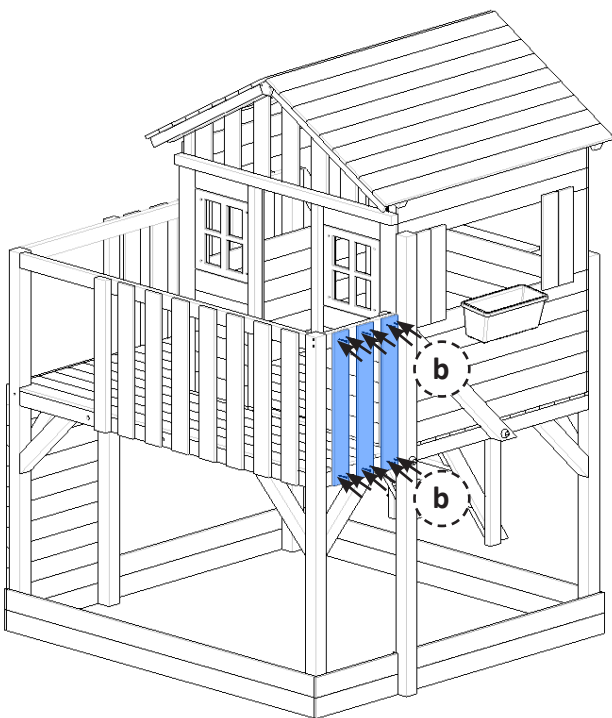

X3 - TU
 X1 - a
 X11 - b

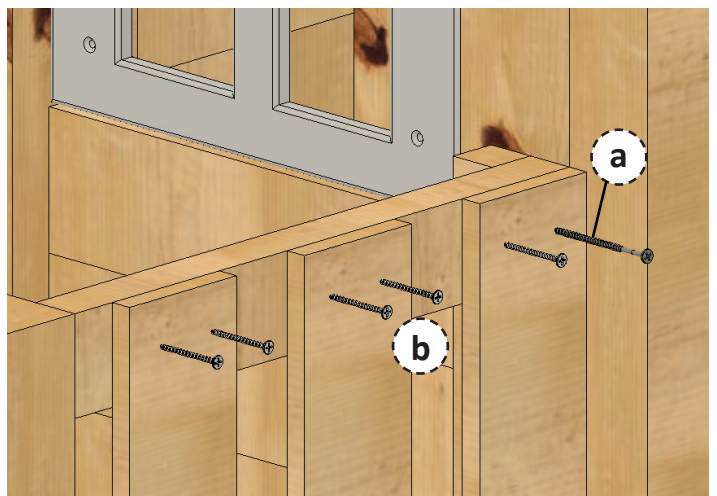

ESP Presione la madera TU con la madera GA, instalada en el paso 44.
ENG Press wood TU to wood GA, installed in step 44.
FRA Appuyez le bois TU sur le bois GA, installé à l'étape 44.
PT Pressione a madeira TU na madeira GA, instalada no passo 44.
CAT Presioni la fusta TU amb la fusta GA, instal·lada al pas 44.

50

X2 - g
X1 - II

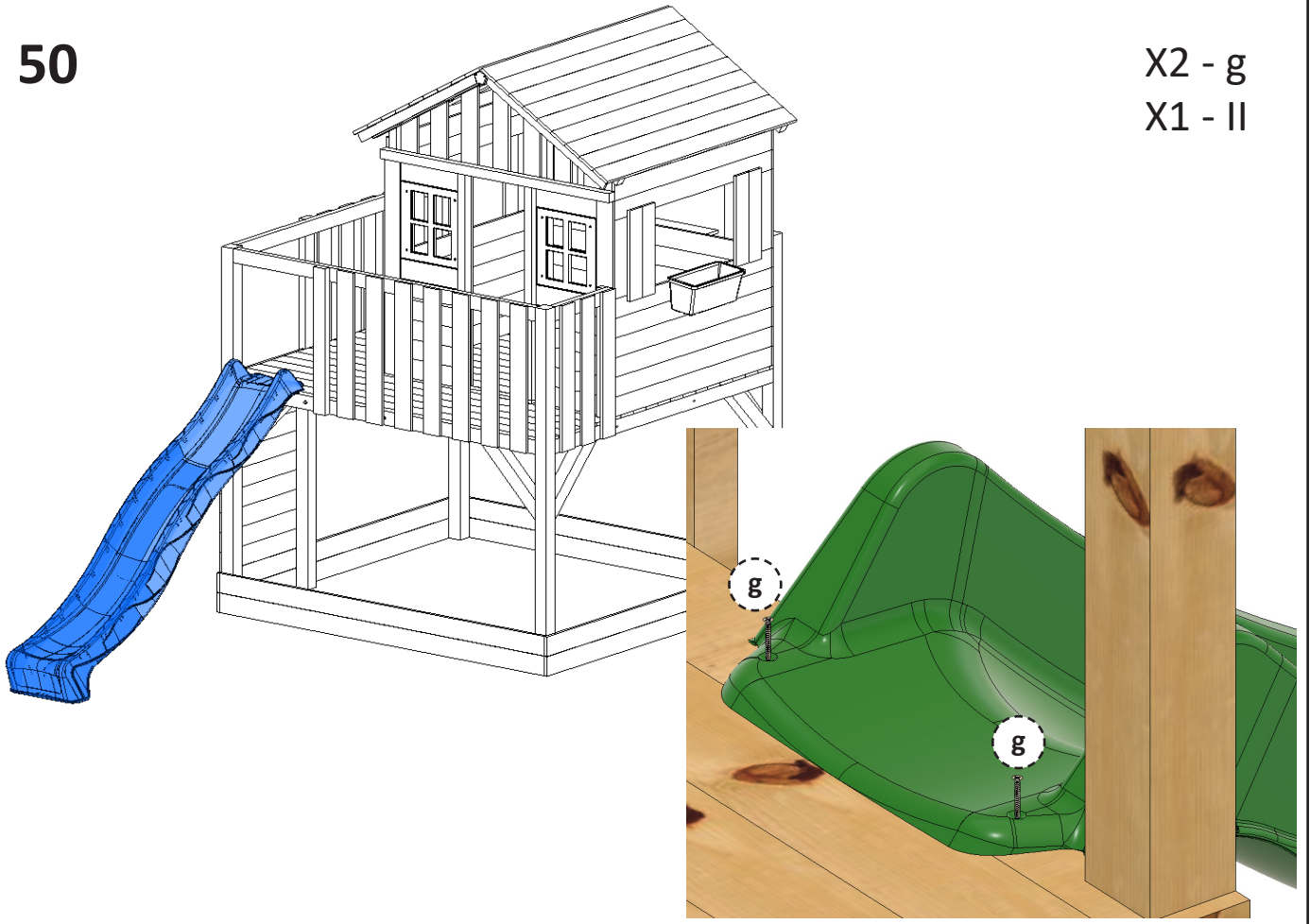

Advertencia
Warning
Attention
Aviso
Advertència

ESP DETALLE CIMENTACIÓN
ENG FOUNDATION DETAIL
FRA DÉTAIL DE LA FONDATION
PT DETALHE DA FUNDAÇÃO
CAT DETALL DELS FONAMENTS

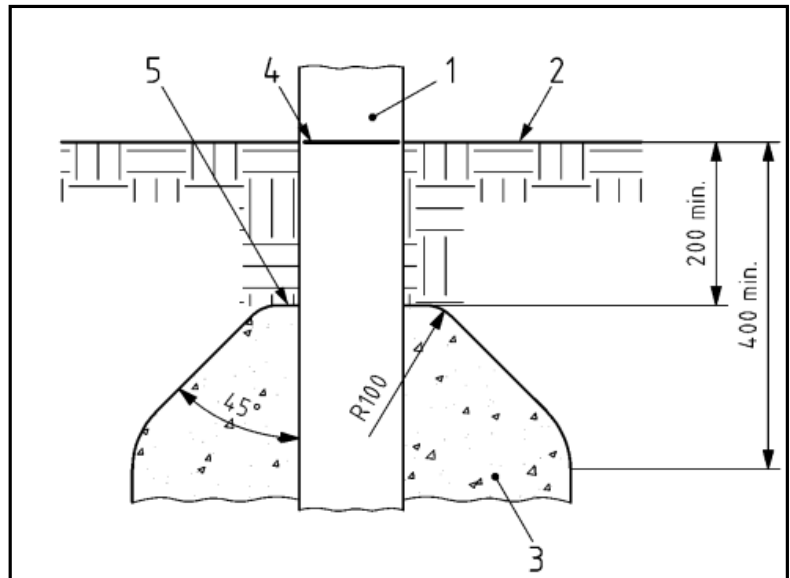

- 1 - Pilar/Pillar/Piller/Pilar/Pilar
- 2 - Superfície de juego/ Playing surface/ Surface de jeu/ Superfície de jogo/ Superfície de joc
- 3 - Cimentación/Foundation/ Fondation/ Fundação/Fonaments
- 4 - Línea de base/Baseline/ Ligne de base/ Linha de base/ Línia de base
- 5 - Límite de cimentación/Foundation limit/ Limite de fondation/ Limite de fundação/ Límit dels fonaments

51

X2 - h
X2 - p
X2 - GG

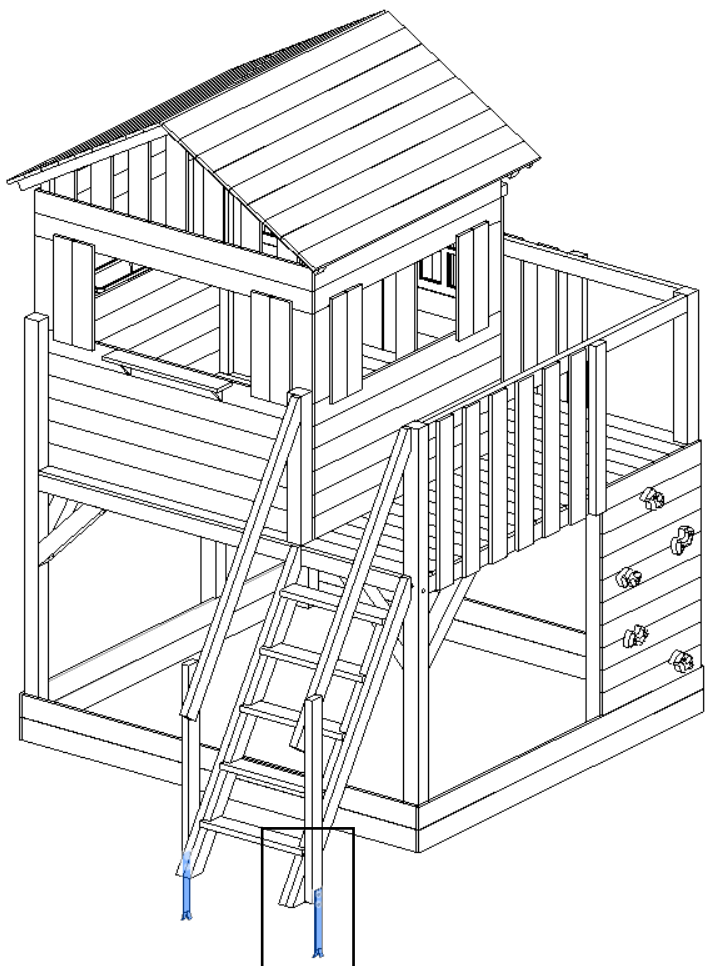
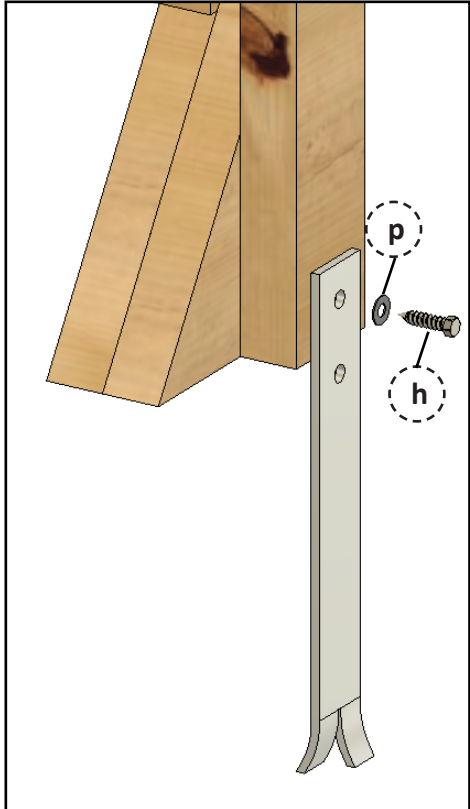

52

X2 - HH

